



# SUPERSCAN-T USER'S GUIDE

## PRESENCE SENSOR w/MONITORING

### DESCRIPTION

The SuperScan-T detector is a door-mounted presence detection system that is used on automatic pedestrian swing doors. The SuperScan-T can be used on a monitored or non-monitored system. Unlike other door-mounted sensing devices, the SuperScan-T's unique electronic architecture allows the detection modules to be mounted near the top of the door, out of harm's way. A rotating cam is used for the range adjustment of the detection zone. Width patterns may be altered by adding Slave modules to the Master module. These Slave modules are simply added by inserting them into the aluminum extrusion, then connecting them with the attached flat ribbon cable to the next module without interrupting other modules in the same extrusion. Once installed, the detection zone (in addition to being adjustable for distance) can be angled independently from the other modules.

Each SuperScan-T module consists of two optics, a transmitter (TX) and a receiver (RX), and functions independently of the other modules. The transmitter emits an extremely precise beam, which measures approximately 4" in diameter at a distance of 8'. The receiver, in turn, receives the infrared beam reflected off of the floor. This transmission and reception forms a detection triangle, which is the basic premise of detection (called triangulation). Should this angle be interrupted, detection will occur. Detection is NOT based upon the intensity of the beam, and in principle will not be affected by the color or background of the object that interrupts the angle.

### TECHNICAL SPECIFICATIONS

DESCRIPTION	SPECIFICATION
Power Supply	12 – 24 VAC/VDC ±10%
Current Consumption	Master: On = 60 mA max. Off = 30 mA max. Slave: On = 40 mA max. Off = 30 mA max.
Inhibit Input	12 – 24 VAC/VDC ±10% (inhibited when voltage is applied)
Monitoring Request Input	12 – 35 VDC required (polarity-sensitive) Min. pulse width duration 50 ms
Output Interface; relay	Relay – max. contact rating is 1A @ 30v (resistive)
Detection Range	0 – 8'
Distance Adjustment	2 – 8' (rotating cam with linear adjustment)
Max. Mounting Height	8'
Detection Time	< 50 ms
Detection Signal Duration	Infinite Presence Detection
Output Hold Time	Potentiometer range: 0.1 – 4.5 seconds
LED Indications	Master: Red LED = Detection Green LED = Active Output Slave: Red LED = Detection
Operating Temperature Range	-30 – 140 °F
PCB Dimensions	Master: 10.91" x 1.5" Slave: 8.75" x 1.5"
Connector to Door Controller	8-position screw terminal on Master PCB
Connection: Master to Slave	Flat-ribbon cable w/connectors and key lock
Max. Number of Slaves	8
Functions Selection	Detection Mode: NO or NC Normal Mode or Background Analysis Mode

### SAFETY PRECAUTIONS



CAUTION

- Shut off all power going to the header before attempting any wiring procedures.
- Maintain a clean and safe environment when working in public areas.
- Constantly be aware of pedestrian traffic around the door area.
- When performing testing, always stop pedestrian traffic through the doorway that may result in unexpected reactions by the door.
- Before powering up, always check placement of all wiring and components to ensure that moving door parts will not catch any wires and cause damage to equipment.
- Ensure compliance with all applicable safety standards (i.e. ANSI A156.10, 156.27) upon completion of installation.

### COMPONENT ID

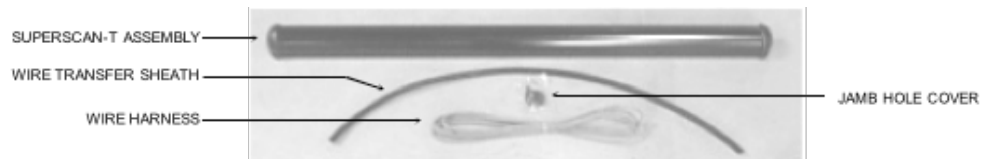

**INSTALLATION TIPS**



- ❑ The sensor must be firmly fastened to prevent vibration.

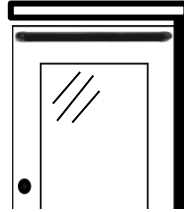

- ❑ Sensor must be in a location that does not interfere with door hardware (finger guards, lock rods, etc.).

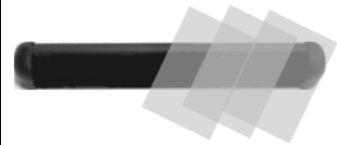

- ❑ The sensor must not have any unwanted objects likely to move or vibrate in its path.

**MECHANICAL INSTALLATION**

**PREPARING AND MOUNTING THE SENSOR**

1. Remove the screw that secures the endcap to the SuperScan-T extrusion (image below, left).

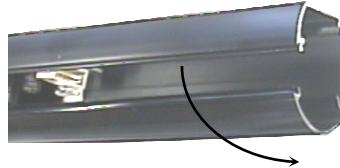
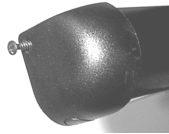

2. Remove the plastic lens by pulling the lens out from the top of the extrusion (image above, right). Do not use a screwdriver to pry the lens, as cracking may occur.



**CAUTION!** REMOVE THE MASTER AND ALL SLAVE CIRCUIT BOARDS FROM THE ALUMINUM EXTRUSION BEFORE PERFORMING ANY DRILLING.

WHEN COMPLETE, ENSURE THAT ALL METAL SHAVINGS ARE CLEANED FROM THE EXTRUSION BEFORE RE-INSERTING THE CIRCUIT BOARDS.

3. The image below (left) shows the angle adjustment clip in its proper position within the extrusion (PCBs removed and clip shown at end of extrusion for clarity only). To remove the clip, simply pull the tab out away and downward from the extrusion, then rotate the module out from extrusion (image below, right). To re-install, simply reverse the procedure. The PCB must first be installed into the adjustment clip, then installed into the aluminum extrusion.

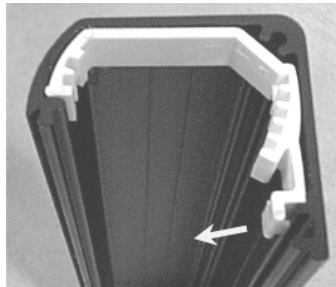

**IMPORTANT NOTE:** The end of the extrusion that is towards the pivot end of a center-hung door, should be in far enough from the edge of the door (image below, left) to prevent the endcap of the SuperScan-T from rubbing against the finger guard during door movement. Pay particular attention on the safety side of the door. Hinge-hung doors will not require as much clearance between the end of the SuperScan-T and hinge-side jamb (image below, right). At the leading edge of the door, the edge of the SuperScan-T, including the endcap, should be as close as possible to the leading edge of the door, without creating mechanical interference with the door jamb or with an adjacent door (pairs).

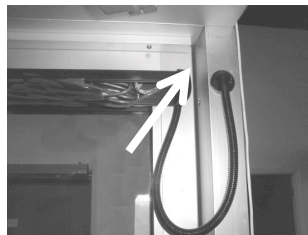

4. Hold the SuperScan-T extrusion up to the top of the door. Ensure that the extrusion is oriented correctly.

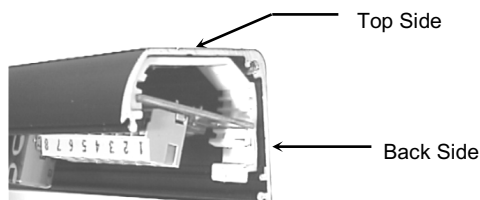

5. Mark and drill the extrusion (in the approximate locations as shown below) where the mounting holes (one at each end) should be located. Also, be sure to mark and drill the proper end for an additional hole to be used for wire passage. Wire passage hole should be approximately  $\frac{1}{4}$ " diameter. Screw mount holes only serve as a pilot hole for ease of installing the self-drilling screws that are provided.

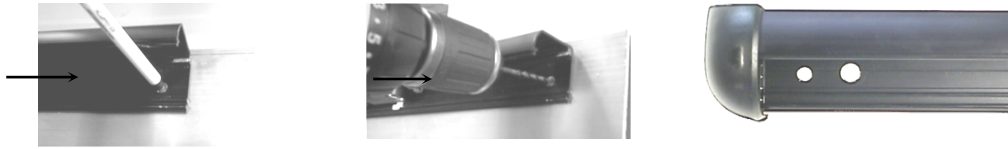

**NOTE:** Take care to avoid screw holes near the seams of the door. It may be difficult to drill and install a screw, and may possibly damage the inside structural braces of the door.

6. Hold the SuperScan-T back up to the door at the pre-drilled location and attach the unit to the door with the 2 screws provided. Ensure that the SuperScan-T extrusion is tight against the door.



7. If SuperScan-Ts are to be mounted on both sides of the door, a wire passage hole will be required through the door to go from the approach side to the safety side, as shown below. Again, be sure not to drill through any through-bolts or braces within the door. A The extension wire going between the terminal blocks should be approximately 18" long and can then be cut back as needed.

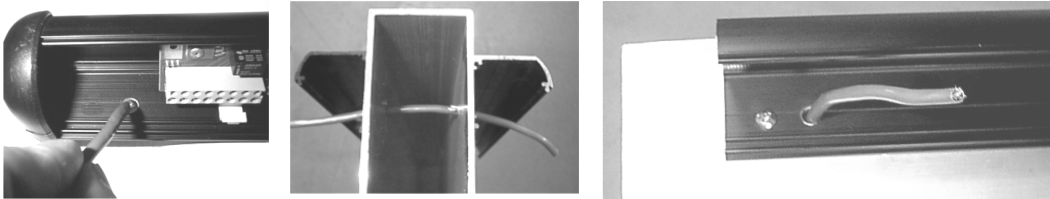

8. Next, a wire passage hole will be required in the door header (image below, left) and also in the jamb tube (image below, right) at approximately the same height as the SuperScan-T. The wire transfer hole in the jamb should be at the secure side of the door. Normally, this will be the interior side. Feed the wire through the jamb tube up to the header. Ensure that enough wire is left out to reach the SuperScan-T terminal block.



**NOTE:** Ensure that there is enough slack in the cabling to allow for adequate movement of the cable throughout the range of door travel.

9. Once all cabling is in place, the plastic sheath must be installed over the wire coming out of the jamb tube. This must be done before making final connection to the terminal block. The sheath may have to be cut to fit the application. Once the wire is fed though, the plastic cap may be installed on the jamb, over the transfer hole.

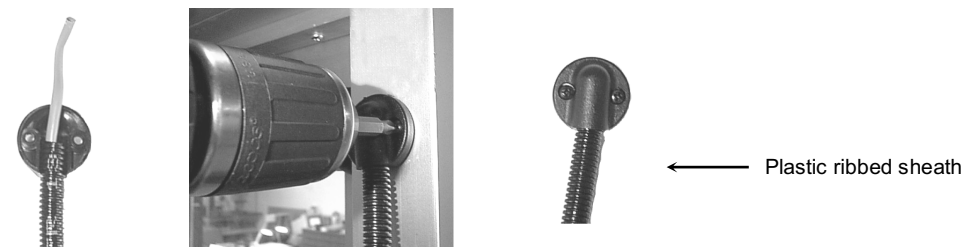

1. With cabling in place, wiring at the terminal connector (image below, left) on the SuperScan-T Master module may be completed. Wiring will vary according to the application. Available positions on the connector are shown below:

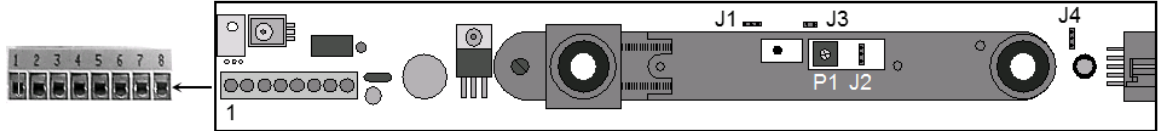

Terminal	Explanation of Wiring Connections
1	<b>Test input</b> (when used as a monitored sensor) <b>(+) positive when utilizing monitoring</b>
2	<b>Ground</b> <b>(-) negative when utilizing monitoring</b> Negative terminal if Input inhibition is used
3	<b>Input inhibition:</b> All detection is ignored. Infrared emission is stopped. Inhibition occurs when 12 – 24 VAC/VDC $\pm 10\%$ is applied between terminal 3 and terminal 2.
4	<b>Normally Open:</b> JP2 factory default will <u>close</u> the relay contact on terminal 4 when the SuperScan-T is energized and not in detection. Loss of power results in a <u>N.O.</u> contact
5	<b>Normally Closed:</b> JP2 factory default will <u>open</u> the relay contact on terminal 5 when the SuperScan-T is energized and not in detection. Loss of power will result in a <u>N.C.</u> contact.
6	<b>Common</b> contact for relay
7	<b>Power Input (-):</b> 12 – 24 VAC/VDC $\pm 10\%$ must be supplied
8	<b>Power Input (+):</b> 12 – 24 VAC/VDC $\pm 10\%$ must be supplied

2. Once all wiring has been completed, the endcaps and lens may be installed. At the SuperScan-T end of the cable (image below, A), leave enough slack to allow a relaxed connection at the terminal block. Locate the SuperScan-T endcap that goes towards the hinge-end of the door. Remove the tab at the bottom of the cap (image below, B) to allow insertion of the plastic sheath. Insert the plastic sheath (image below, C) and install the endcap. The SuperScan-T lens may then be installed to fit tight against the endcap and plastic sheath to hold it in place (image below, D). Leave the endcap off at the opposite end until all mechanical adjustments have been completed.

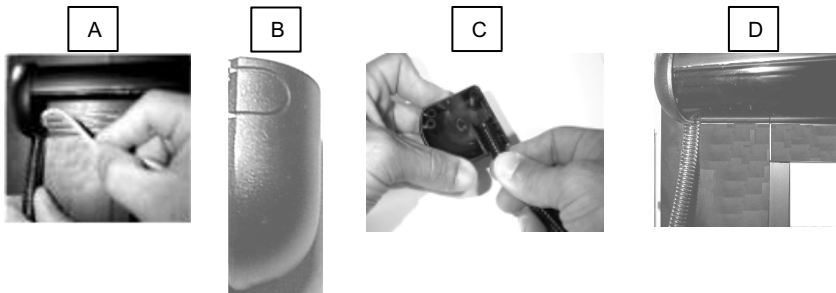

\* Refer to the appendices of this document for various wiring schematics.

**Master and Slave Module Jumper Settings:** Prior to power-on, all jumper settings on the Master and Slave boards should be set according to the installation.

Jumper settings include:

- Function J1: Background Analysis (Master and Slave boards)
- Function J2: Relay Mode (NO / NC) (Master board only)
- Function J3: Monitoring Mode (Master board only)
- Function J4: Master Only or Master and Slave Configuration (Master and Slave boards)

1. Jumper J1 (Background Analysis) is a 3-pin configuration located on each module. Background Analysis is the ability to analyze the background in the area of the detection field, to help reduce chances of non-detection due to faulty environmental situations. When ON, Background Analysis allows constant detection in the event of one or more of the following situations:
  - Module aimed too high
  - Module incorrectly oriented (towards sky, for example)
  - Defective amplification chain
  - Faulty infrared transmitter
  - Not enough reflectivity off of floor surface

**NOTE: Floor must have at least 5% reflectivity to allow Background Analysis to function properly.**

This configuration greatly reduces the chance of allowing the modules to function less than optimally. If one of the above-stated faults exists, the detector will remain active, thereby causing the door to stay open or to not open. This fail-safe operation will cause the door to be inoperative in the automatic mode, since there will be a constant signal either to the safety input or to the activation input of the door control, depending on which module is sensing detection. If an extremely IR-absorbent floor is present, set J1 to Background Analysis mode. **The J1 function must be set on each module.**

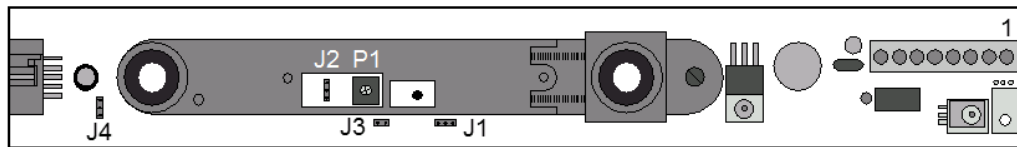

**Background Analysis Mode – 3-Pin Jumper:** Center pin and left pin are for Normal Mode, center pin and right pin are for Background Analysis mode.

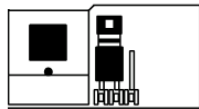

3-Pin  
Normal Mode  
(Default)

J1

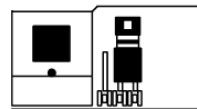

3-Pin  
Background Analysis Mode

J1

2. J2 is a two-position jumper (**ON THE MASTER BOARD ONLY**), which enables either a passive or active relay to be selected. The SuperScan-T comes factory-preset with the relay in the ACTIVE MODE.

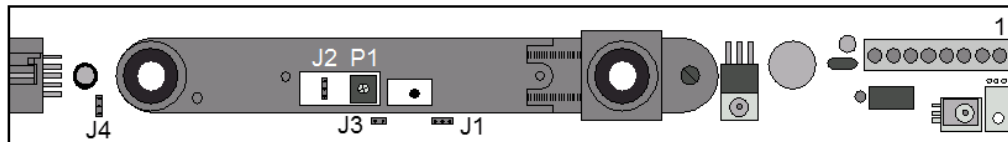

**ACTIVE RELAY: RELAY ENERGIZED WHEN DETECTOR IS AT REST**

ACTIVE RELAY + NC & COM TERMINAL CONNECTION = **CLOSED CONTACT DURING DETECTION**

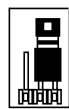

View Looking  
Toward P1

J2



- Use the NC and COM terminals (5 and 6) and leave JP2 at the factory-preset position.
- LED indication during detection: Green LED is OFF, red LED is ON
- Upon power loss, the contact will be closed.

ACTIVE RELAY + NO & COM TERMINAL CONNECTION = **OPEN CONTACT DURING DETECTION**

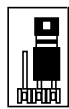

View Looking  
Toward P1

J2



- Use the NO and COM terminals (4 and 6) and leave JP2 at the factory-preset position.
- LED indication during detection: Green LED is OFF, red LED is ON
- Upon power loss, the contact will be open.

**PASSIVE RELAY: RELAY DE-ENERGIZED WHEN DETECTOR IS AT REST**

PASSIVE RELAY + NO & COM TERMINAL CONNECTION = **CLOSED CONTACT DURING DETECTION**



- Use NO and COM terminals (4 and 6) and **CHANGE JP2** from the factory-preset position.
- LED indication during detection: Green LED is ON, red LED is ON
- Upon power loss, the contact will be open.

PASSIVE RELAY + NC & COM TERMINAL CONNECTION = **OPEN CONTACT DURING DETECTION**



- Use the NC and COM terminals (5 and 6) and **CHANGE JP2** from the factory-preset position.
- LED indication during detection: Green LED is ON, red LED is ON
- Upon power loss, the contact will be closed.

3. Jumper J3 (located only on Master module) is to toggle the monitoring mode on and off.

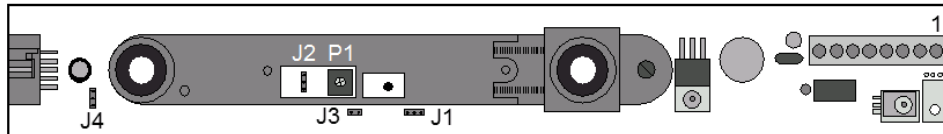

- Monitoring OFF = jumper installed on both pins (image below, left)
- Monitoring ON = jumper removed (may be stored on one pin) (image below, right)
- Monitoring is not available on Master modules without jumper J3 installed.

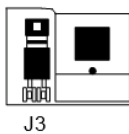

Monitoring 'OFF'

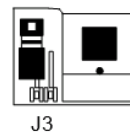

Monitoring 'ON'

4. Jumper J4, is found on the Master and Slave modules. On the Master module, it determines 'Master only' or 'Master and Slave' configuration for use when Monitoring is ON.

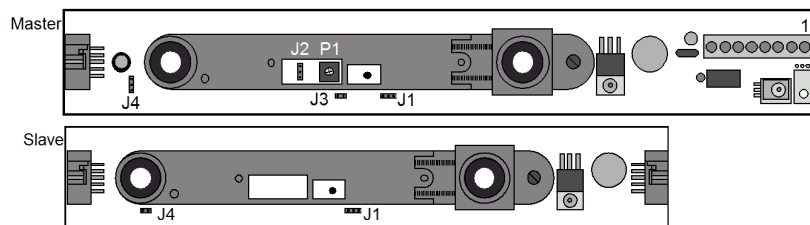

When the jumper is installed in 'Master only' configuration (image right, top), it is intended for use without Slave modules added to the chain and is for 'Master only' operation. The jumper is located at the Output end of the Master module. ('Master only' has jumper installed on two pins closest to center of board.)

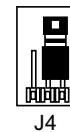

View Looking Toward  
Master Output

With jumper J4 installed as shown in the image to the right (middle), the Master is intended for Slave modules to be added. Jumper J4 is also installed on the last Slave module in the multi-module chain, near the output end of the module.

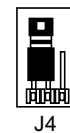

View Looking Toward  
Master Output

As shipped From BEA, Inc., default placement of J4 jumpers is as follows:

- If a Master ONLY is shipped: Jumper will be positioned for Master Only
- If a Slave ONLY is shipped: No jumper on Slave J4 position
- If a kit is shipped (i.e. SuperScan-T II): Jumpers correctly for monitoring in that configuration.

On the Slave module, jumper J4 should be installed on the last Slave module in the chain, as shown in the image to the right (bottom). All Slave modules between the Master and the last Slave should have the jumper removed.

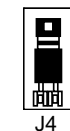

View Looking Toward  
Master Output

There is a hold-time potentiometer (P1) located on the Master module. It is located between the receiver and transmitter. Adjustability ranges from 0.1 – 4.5 seconds. When installed, clockwise rotation increases time delay.

**MECHANICAL ADJUSTMENTS**

**POSITIONING AND ANGLING THE MODULES**

- The positioning of the modules within the aluminum extrusion will be as shown below. The modules will always be positioned so that the transmitter (TX) is at the leading-edge of the door. Modules may be flipped around to accommodate handing of doors.

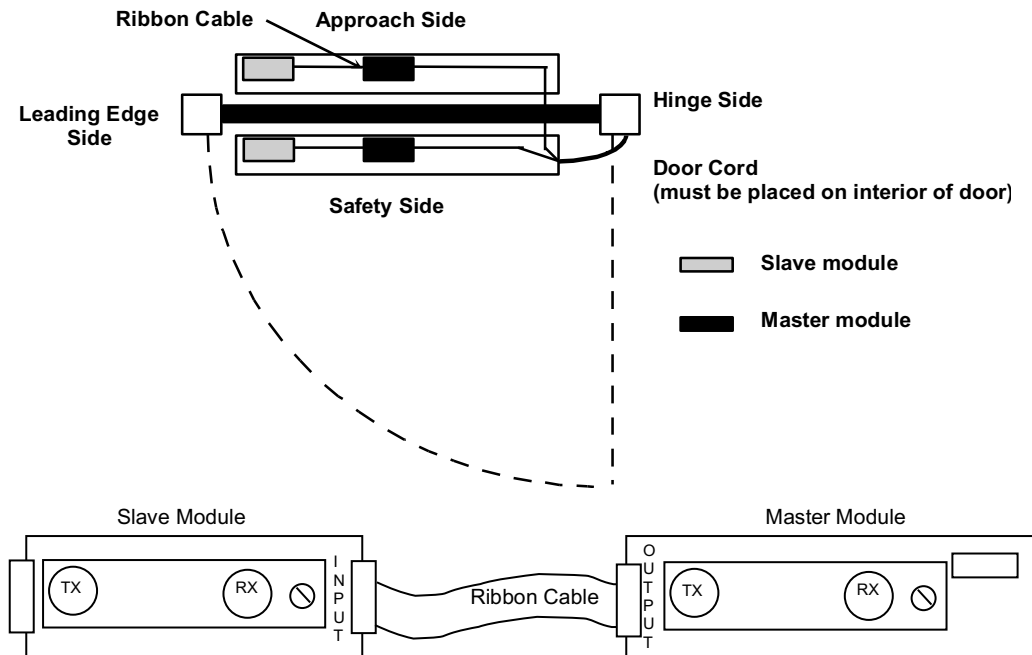

- The angle of each module may be set independently. Use the charts below to help determine the angling. The angles may have to be altered once the units have been powered up and walk-tested.

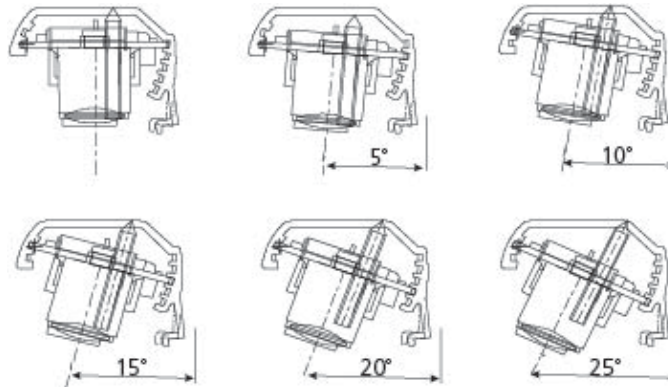

INACTIVE ZONE (B) DISTANCE FROM FLOOR	SUPERSCAN-T ANGLE					
	0°	5°	10°	15°	20°	25°
8"	0	6"	12 1/2"	19 1/4"	26"	33 1/4"
12"	0	6"	12"	18"	24 1/2"	31 1/2"
16"	0	5 1/2"	11 1/4"	16 3/4"	23 1/4"	29 1/2"
20"	0	5 1/4"	10 1/2"	16"	21 1/2"	27 1/2"

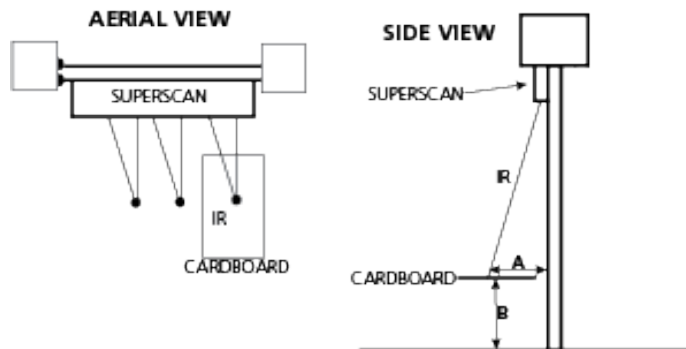

**MECHANICAL  
ADJUSTMENTS**

**POSITIONING AND  
ANGLING THE  
MODULES**

3. The following procedures will be used to adjust each module's detection zone upon power-on, and must be made with the Background Analysis jumper set to 'Normal Mode' (see page 5).
  - a. Power the sensors with 12 – 24 VAC/VDC  $\pm$ 10%. LED status should reflect what was configured for the relay output (see page 6)
  - b. Use a white, gray, or black piece of cardboard about 8" x 11" and hold it as shown in the diagram in step 2 of this section (previous page).
  - c. Move the cardboard from the floor upward until it is detected. This will determine the height of the inactive area (B distance).
  - d. Measure the height at which the cardboard was detected.
  - e. If this height does not fall between 12" – 16" above the floor or does not meet your requirements, an adjustment must be made to the detection distance. *One notch of the distance adjustment corresponds to approximately 4".*

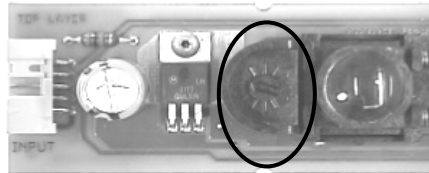

Detection Distance Adjustment

- If Zone B is too high, turn the distance adjustment clockwise to increase the detection distance and decrease Zone B.
- If Zone B is too low, turn the distance adjustment counter-clockwise to decrease the detection distance.

Per current ANSI A156.10, 156.27 the detection zone must be within 28" of the floor. Ideally, each detector should be adjusted so that detection occurs at 12" – 16" above the floor. Less than 12" of Zone B may result in occasional false triggering of the sensor.

- f. Once all sensors have been adjusted, activate the door several times and allow it to go through a full cycle each time. Ensure that no false triggering is occurring, as would be indicated by the door re-cycling or stopping by itself at any point of travel.
- g. Ensure compliance of all applicable safety standards (i.e. ANSI A156.10, 156.27).
- h. Install all remaining covers, endcaps, screws, etc.

**MONITORING &  
NON-MONITORING  
COMPATIBILITY**

When using monitoring and non-monitoring modules in the same chain, observe the following rules:

- Non-monitoring Master modules **CANNOT** be used with monitoring Slave modules.
- All other combinations will work; however, for a system to utilize monitoring, all modules must be monitoring modules

**TROUBLE-  
SHOOTING**

PROBLEM	POSSIBLE CAUSE	CORECTIVE ACTION
SuperScan-T does not work at all. No LED indications.	Faulty power supply Faulty connections	Power supply must be 12 – 24 VAC/VDC $\pm$ 10%. Check for this power at terminals 7 and 8 of the affected SuperScan-T module.
SuperScan-T output appears to be working opposite of what is expected.	Relay output may be configured improperly	Observe the LED indications on the affected modules to help determine status.
Door stops by itself before reaching the full-open position.	Safety-side SuperScan-T may be seeing an adjacent wall or rail behind the door near the open position	Observe the LED status on safety side of door. Find the SuperScan-T module that is being falsely triggered. Check for: <ul style="list-style-type: none"> <li>✓ Proper detection angle</li> <li>✓ Detection range adjustment</li> </ul> SuperScan-T may need to be inhibited at a specific point of door travel at the safety side for proper operation. Refer to the terminal connections on page 4.
Activation or safety is being held triggered.	SuperScan-T detection module may be seeing the floor or unwanted object near door	Reduce the detection range on the affected module(s). Detection should occur at 12" to 16" above the floor. Refer to step 3 in "Mechanical Adjustments – Positioning & Angling Modules" (above).
Erratic detection behavior is occurring throughout the door's opening and closing cycle.	Possible faulty wiring at door transfer location	Using a multi-meter, check each wire for continuity at the transfer location. Move the wires around during testing to help locate any breaks. Replace faulty wiring as necessary.



ACCESSORIES

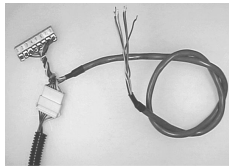

PN: 10SSQD  
Quick Disconnect  
Cable

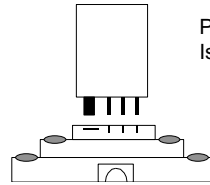

PN: 10REL24V  
Isolation Relay



PN: 10BR3  
Interface module



Upon completion of the installation or service work, at a minimum, perform a daily safety check in accordance with the minimum inspection guidelines provided by AAADM. Provide each equipment owner with an owner's manual that includes a daily safety checklist and contains, at a minimum, the information recommended by AAADM. Offer an information session with the equipment owner explaining how to perform daily inspections and point out the location of power/operation switches to disable the equipment if a compliance issue is noted. The equipment should be inspected annually in accordance with the minimum inspection guidelines. A safety check that includes, at a minimum, the items listed on the safety information label must be performed during each service call. If you are not an AAADM certified inspector, BEA strongly recommends you have an AAADM certified inspector perform an AAADM inspection and place a valid inspection sticker below the safety information label prior to putting the equipment into operation.