

# Installation & Instruction Manual

## Commercial & Industrial Heavy Duty Trolley Operator (For standard lift sectional doors)

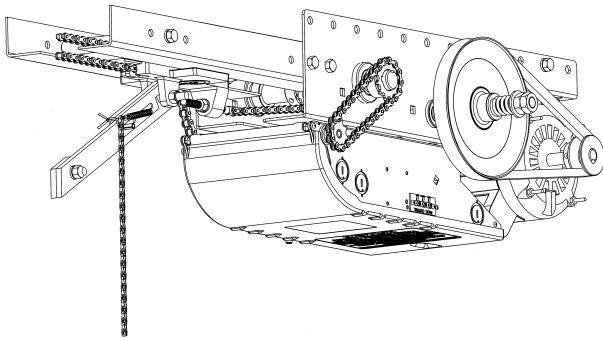

**OTH**

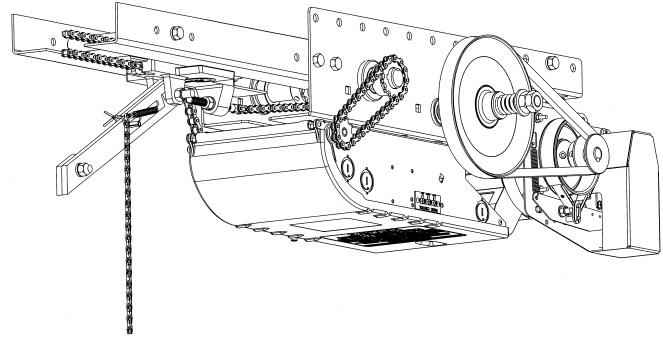

**OTBH**

CSA C22.2-247.92  
UL 325 5th Ed. PRIOR to  
August 2010 revision  
  
154346

### Electrical Control (BOARD 070E)



READ AND FOLLOW ALL INSTRUCTIONS.  
SAVE THESE INSTRUCTIONS.  
GIVE TO END-USER.

Serial # \_\_\_\_\_

Model # \_\_\_\_\_

Wiring Diagram # \_\_\_\_\_

Project #/Name \_\_\_\_\_

Door #/Name \_\_\_\_\_



For technical support, please call 1-800-361-2260 or visit [www.manaras.com](http://www.manaras.com) for more information

## TABLE OF CONTENTS

<b>Installation Instructions.....</b>	<b>3</b>
<b>1 General Specifications and Dimensions (OTH).....</b>	<b>4</b>
<b>2 General Specifications and Dimensions (OTBH &amp; OSL).....</b>	<b>5</b>
<b>3 Door &amp; Operator Hardware.....</b>	<b>6</b>
3.1 Delivery of Operator.....	6
3.2 Hardware Supplied.....	6
<b>4 Operator Installation.....</b>	<b>7</b>
4.1 Assembly Instructions.....	7
4.2 Installation.....	9
<b>5 Disconnect Mechanism.....</b>	<b>11</b>
<b>6 Limit Switches &amp; Limit Cams: Adjustment &amp; Functionality.....</b>	<b>12</b>
6.1 Limit Switch Adjustments: Open and Close Cam Settings.....	12
6.2 Limit Switch Functionality.....	12
6.3 Limit Switch Adjustment.....	13
<b>7 Electrical Wiring.....</b>	<b>14</b>
7.1 Low Voltage (Controls) and High Voltage (Power) Connections.....	15
7.2 Main Power Supply Connection.....	15
7.3 Wall-Button Connection.....	16
7.4 Optional Accessory Connections.....	17
<b>8 Electronic Control Board (ECB) – BOARD 070E.....</b>	<b>20</b>
8.1 General Layout.....	20
8.2 On-Board LED Monitoring Status.....	21
8.3 Electronic Control Board (ECB) Programming.....	23
<b>9 On-Board Radio Receiver.....</b>	<b>26</b>
9.1 Radio Receiver Components and Compatible Transmitting Devices.....	26
9.2 Programming Instructions.....	26
9.3 Radio Control Functions – 1 and 3-Button Transmitters.....	27
<b>10 Operator Start-up.....</b>	<b>29</b>
<b>11 Clutch Adjustment.....</b>	<b>30</b>
<b>User Instructions.....</b>	<b>31</b>
<b>1 Quick Fix Instructions.....</b>	<b>32</b>
<b>Maintenance Instructions.....</b>	<b>33</b>
<b>1 Preventative Maintenance Schedule.....</b>	<b>33</b>
1.1 Mechanical Inspection.....	33
1.2 Electrical Inspection.....	34
1.3 Band Brake Maintenance.....	35
1.4 Drum Brake Adjustment (Premium Apartment Trolley or BRAKE014/015).....	37
<b>2 Troubleshooting Guide.....</b>	<b>38</b>
<b>3 Electrical Drawings.....</b>	<b>40</b>
3.1 1 Phase Operator with BOARD 070E.....	40
3.2 3 Phase Operator with BOARD 070E.....	41
3.3 External Wiring with BOARD 070E.....	42
<b>4 Mechanical Exploded Views and Replacement Components.....</b>	<b>43</b>
4.1 OTH / OTBH.....	43
4.2 OTBH Brake.....	44
4.3 OTH / OTBH Control Box with BOARD 070E.....	45
4.4 Replacement Motors, Transformers, Solenoids and Resets.....	46
<b>Notes.....</b>	<b>47</b>
<b>Warranty.....</b>	<b>51</b>

## **Installation Instructions**

# **IMPORTANT INSTALLATION INSTRUCTIONS**

### **WARNING**

## **TO REDUCE THE RISK OF SEVERE INJURY OR DEATH TO PERSONS:**

1. READ AND FOLLOW ALL INSTALLATION INSTRUCTIONS.
2. Install only on a properly operating and balanced door. A door that is operating improperly could cause severe injury. Have qualified service personnel make repairs to cables, spring assemblies and other hardware before installing the operator.
3. Remove all pull ropes and remove, or make inoperative, all locks (unless mechanically and/or electrically interlocked to the power unit) that are connected to the door before installing the operator.
4. Installation of this door operator must be done by a qualified installer.
5. Verify that the operator is correct for type, size of door and frequency of use per the operator specifications.
6. Install the door operator at least 8 feet (2,44 m) or more above the floor if the operator has exposed moving parts. Covers or guarding, provided by the manufacturer, must be installed when the operator is mounted less than 8 feet (2,44 m) above the floor.
7. Do not connect the door operator to the source of power until instructed to do so.
8. Locate the control station: (a) within sight of the door, (b) at a minimum height of 5 feet (1,5 m) above floors, landings, steps or any other adjacent walking surface so small children cannot reach it, and (c) away from all moving parts of the door.
9. Install the Entrapment Warning Placard next to the control station in a prominent location.
10. For products having a manual release, instruct the end user on the operation of the manual release.
11. If you have any questions about the safety of the door operating system, do not install the operator, contact Manaras-Opera at 1-800-361-2260.

# 1 General Specifications and Dimensions (OTH)

SUPPLY VOLTAGE.....	115, 230 VAC single-phase, 208, 460, 575 VAC three-phase
CONTROL VOLTAGE.....	24 VAC class 2 transformer, 2 amp fuse type ACG
MOTOR.....	Continuous duty 1/2, 3/4 horsepower
DOOR SPEED.....	12" / second
NET WEIGHT (Operator only).....	71 Lbs (32 Kg)
STANDARD WIRING TYPE.....	C2 (momentary contact to open/stop and constant-pressure-to-close)
APPLICATION.....	Heavy duty for standard lift sectional doors
DUTY.....	25 cycles/hour or 80 cycles/day maximum

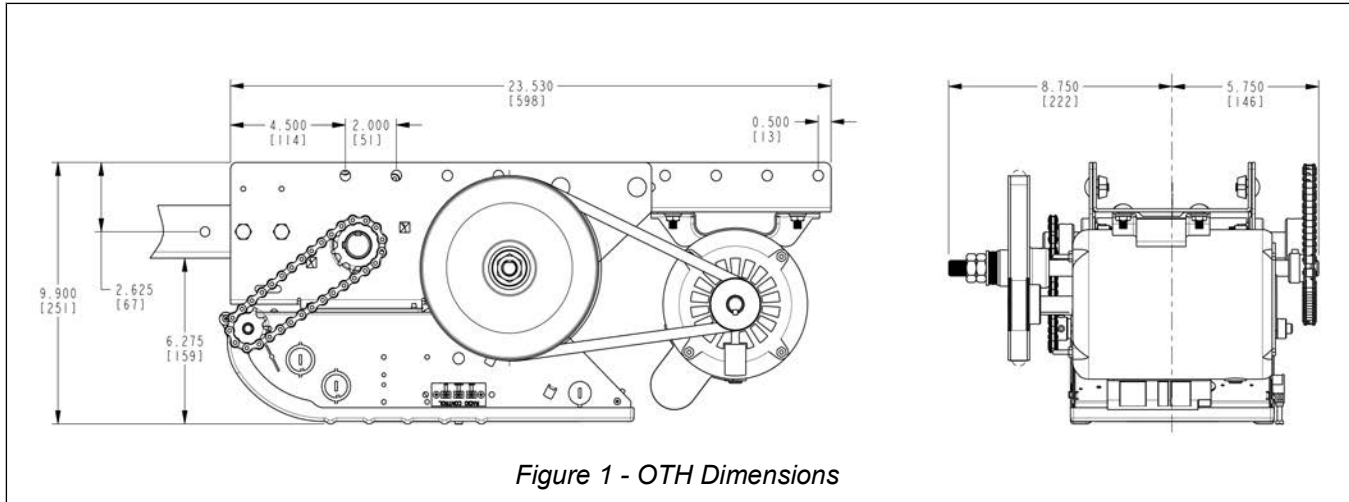

Table 1 - Operator Selection Guide

## Maximum Area in Square Feet (general guideline)

Sectional Doors					
HP	Steel 18 ga ins.	Steel 18 ga 20 ga ins.	Wood Steel 20 ga, 22 & 24 ga ins.	Alu. Steel 22 & 24 ga	Fiber Glass
1/2	196	245	314	343	392
3/4	270	319	441	490	549

## 2 General Specifications and Dimensions (OTBH & OSL)

SUPPLY VOLTAGE.....	115, 230 VAC single-phase, 208, 460, 575 VAC three-phase
CONTROL VOLTAGE.....	24 VAC class 2 transformer, 2 amp fuse type ACG
MOTOR.....	Continuous duty 1/2, 3/4, 1 horsepower
DOOR SPEED.....	12" / second
NET WEIGHT (Operator only).....	73 Lbs (33 Kg)
STANDARD WIRING TYPE.....	C2 (momentary contact to open/stop and constant-pressure-to-close)
APPLICATION.....	Heavy duty for standard lift sectional doors
DUTY.....	25 cycles/hour or 80 cycles/day maximum

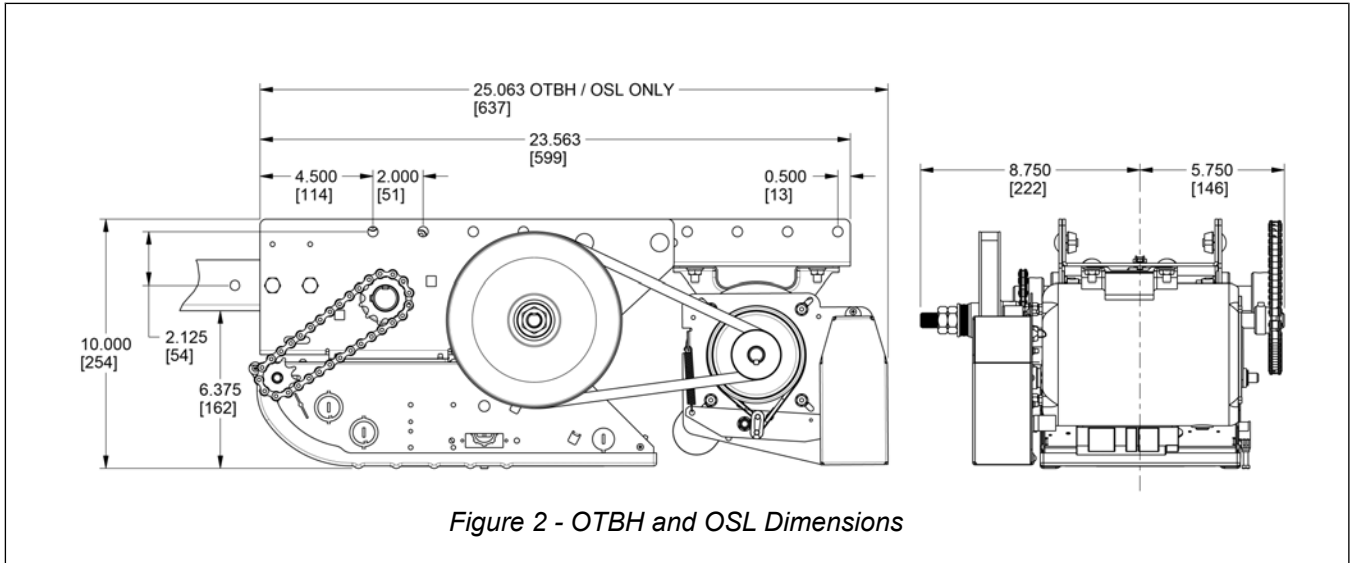

Table 2 - Operator Selection Guide

**Maximum Area in Square Feet (general guideline)**

Sectional Doors					
HP	Steel 18 ga ins.	Steel 18 ga 20 ga ins.	Wood Steel 20 ga, 22 & 24 ga ins.	Alu. Steel 22 & 24 ga	Fiber Glass
1/2	196	245	314	343	392
3/4	270	319	441	490	549
1	294	392	490	564	613

## 3 Door & Operator Hardware

### 3.1 Delivery of Operator

Upon delivery of your OPERA trolley operator, inspect the unit immediately for any shipping damages. Verify that you have received all the hardware parts pertaining to your operator model, as listed in Table 3 and shown in Figure 3. If ordered, other items such as radio controls or other types of optional equipment may be present. If any item is missing or if there is evidence of damage, call the transport company or your direct supplier.

### 3.2 Hardware Supplied

Table 3 - Standard Hardware Parts Supplied

No	Qty	Description	
1	1	3-Push-button station (open/close/stop)	
2	1	Door lifting arm assembly	
3	2	Pre-drilled galvanized track <sup>(1)</sup>	Txxx
4	1	#410 (48)/#41 Drive chain <sup>(1)</sup>	
5	1	Front end u-bracket	
6	1	#410 (48)/#41 Front idler assembly	
7	2	Spacer	
8	1	Carriage	
9	6	Hex bolt 3/8-16 x 1-1/4"	T2- HBAG
10	1	Hex bolt 3/8-16 x 2-1/4"	
11	1	Take-up bolt 3/8-16 x 2-1/2"	
12	1	Connecting chain link	
13	8	Hex nut 3/8-16	
14	7	Helical spring lock washer 3/8	
15	1	Lock nut 3/8-16	
16	1	Entrapment Warning Placard	

(1) Length according to door height

**Note:** Depending on door height, the quantity of track hardware may vary.

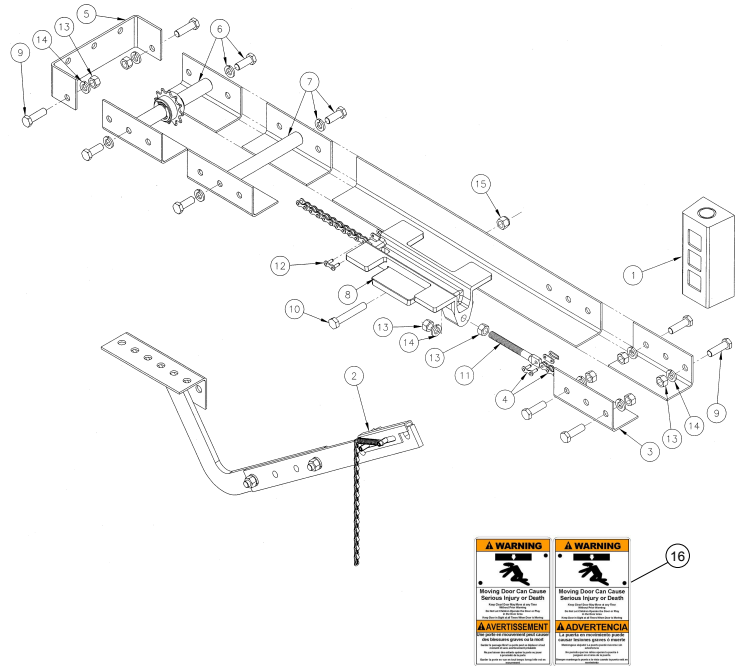

Figure 3 - Standard Trolley Hardware



Figure 4 - Entrapment Warning Placard

**NOTE:** Install the **Entrapment Warning Placard** (shown in Figure 4), next to the control station, visible in the area of the door.

## 4 Operator Installation

### 4.1 Assembly Instructions



## CAUTION

The operator has exposed moving parts and to prevent access to the pinch points, this operator must be installed at least 8 feet (2,44 m) or more above the floor. Alternatively, covers or guarding, provided by the manufacturer, must be installed when the operator is mounted less than 8 feet (2,44 m) above the floor.

## NOTICE

- Install the operator only when all openings of a horizontal slide door are guarded or screened from bottom of the door to a minimum of 4 ft (1,22 m) above the ground to prevent a 2-¼ in (57,2 mm) diameter sphere from passing through the openings anywhere in the door.

### 1 Attach tracks to operator

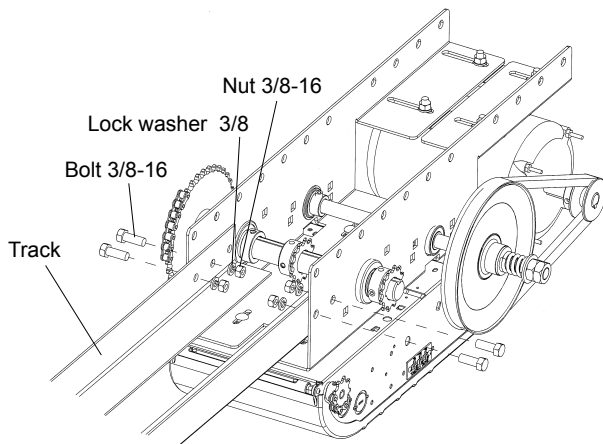

### 2 Assemble carriage

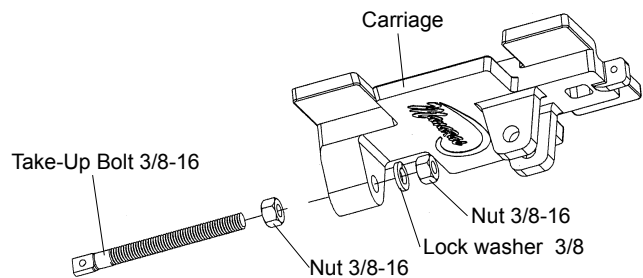

### 3 Slide carriage on track

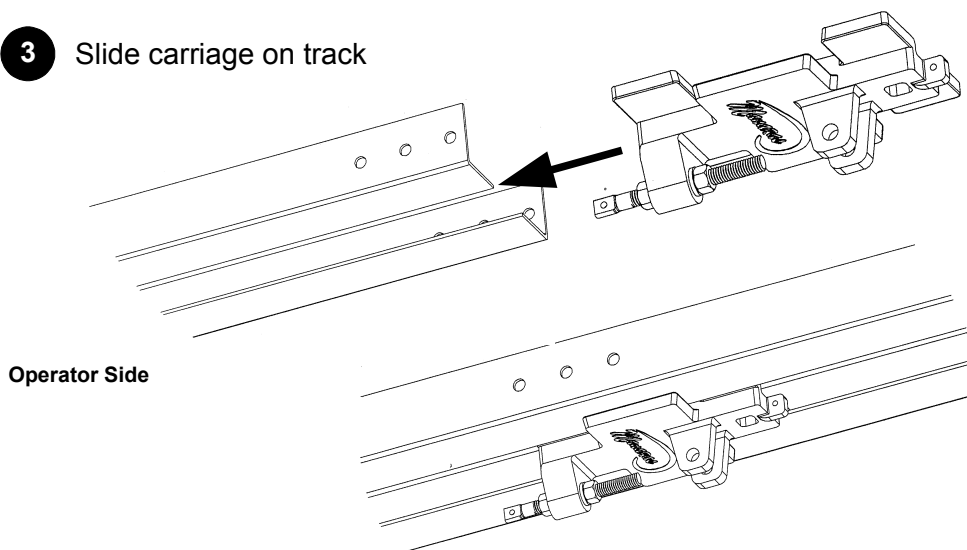

#### 4 Install spacers and front idler

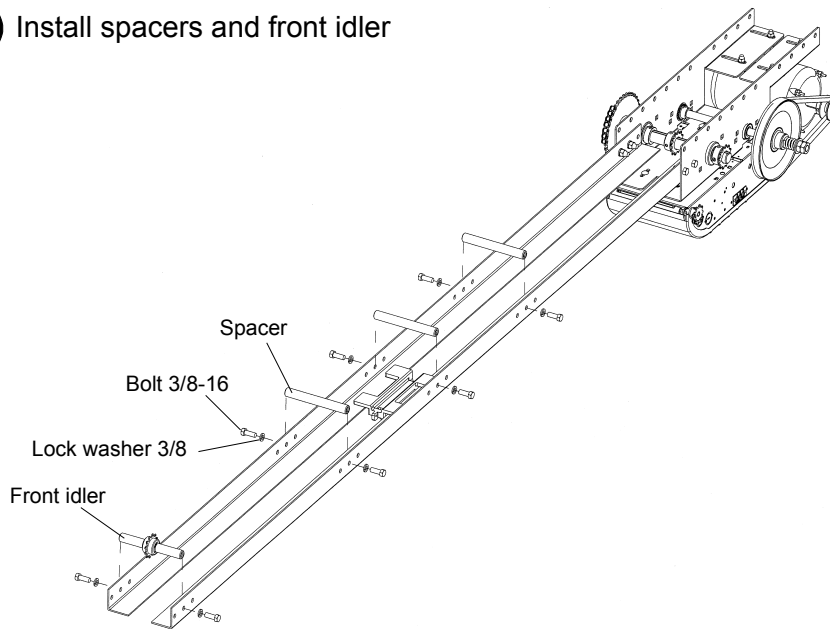

#### 5 Install chain

A) Attach chain to front of carriage.

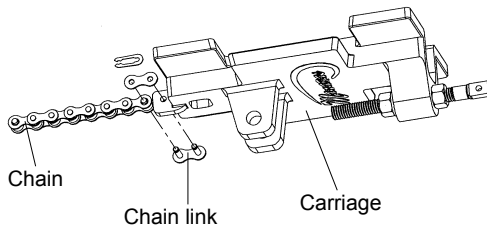

B) Wrap chain around front idler.

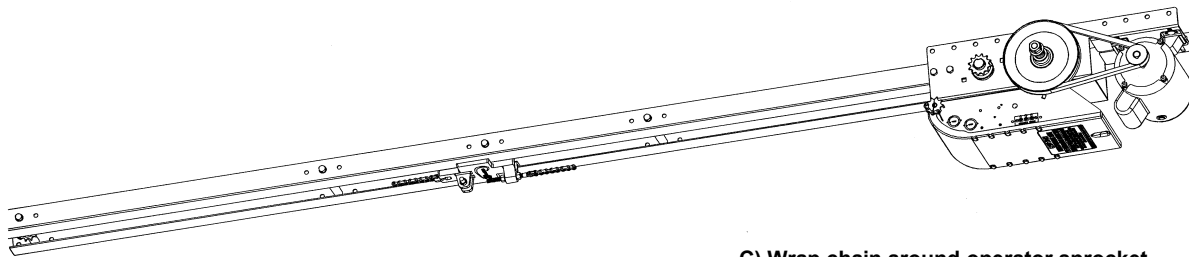
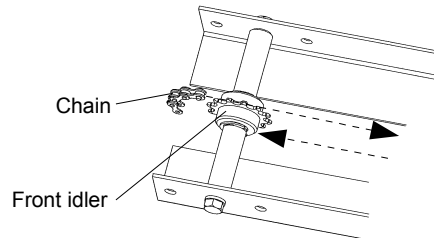

C) Wrap chain around operator sprocket.

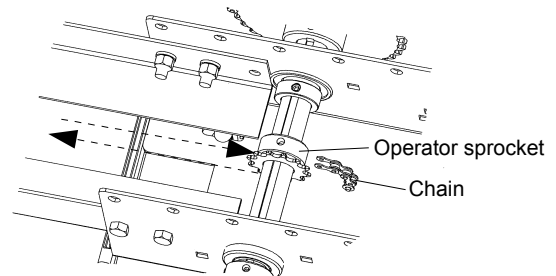

D) Attach chain to back of carriage.

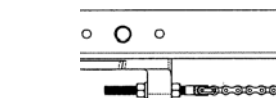
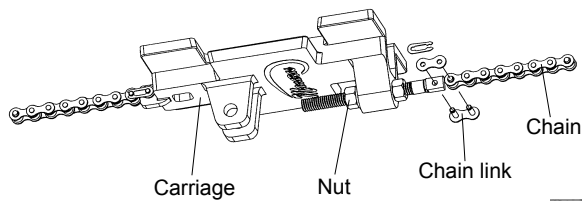

E) Adjust the tension on the chain.



## 4.2 Installation

Trolley operators are designed to be mounted directly over the center of the door. The operator tracks should clear the door by approximately 2.5". Off center mounting may be required, for example, because of potential interfering structures. It is possible to install the operator slightly off the center on torsion spring doors. Extension springs require center mounting.

### 1 Establish the center of the door

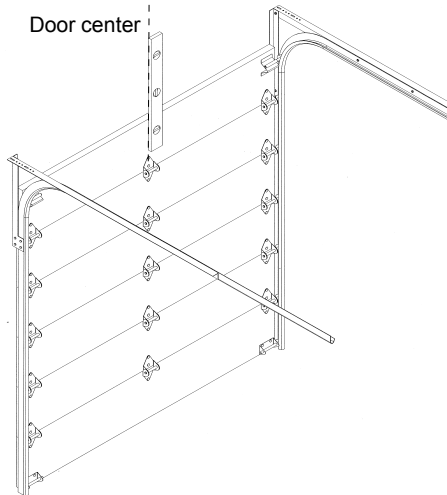

### 2 Establish the highest point of door travel

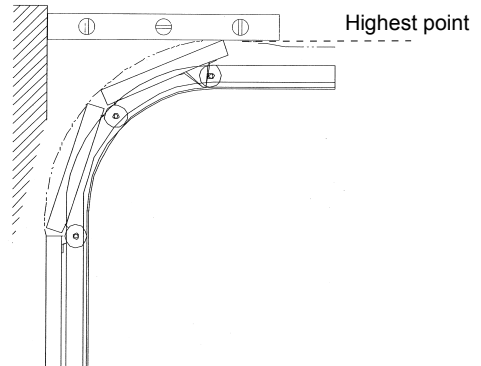

### 3 Position the U-shaped wall bracket

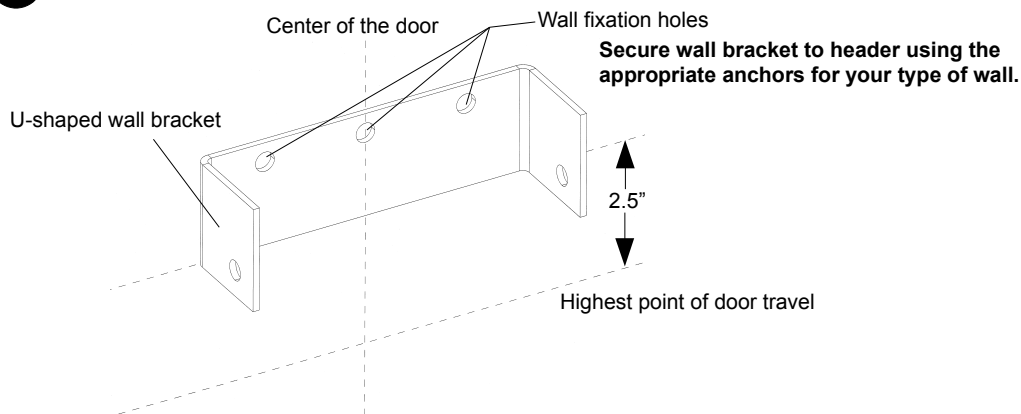

### 4 Attach tracks to U-shaped wall bracket

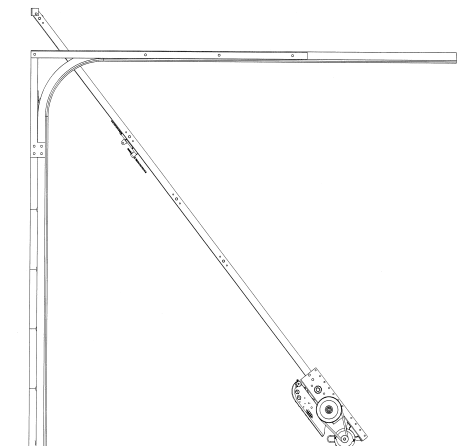

Allow the motor to rest on the floor and raise the front end of the rails and secure with the bolts and nuts (do not tighten).

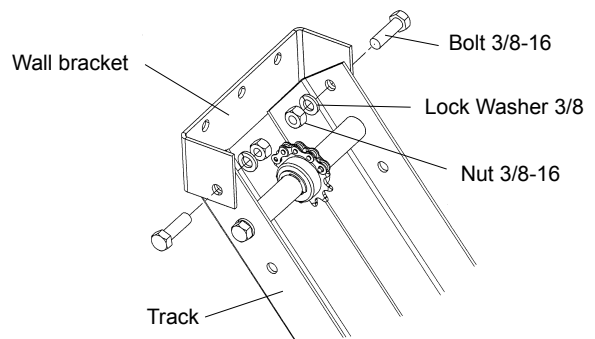

**5** Position and hang the operator

Hoist the rear of the operator to a horizontal position. Temporarily secure with rope or chain. Tighten wall bracket bolts and nuts.

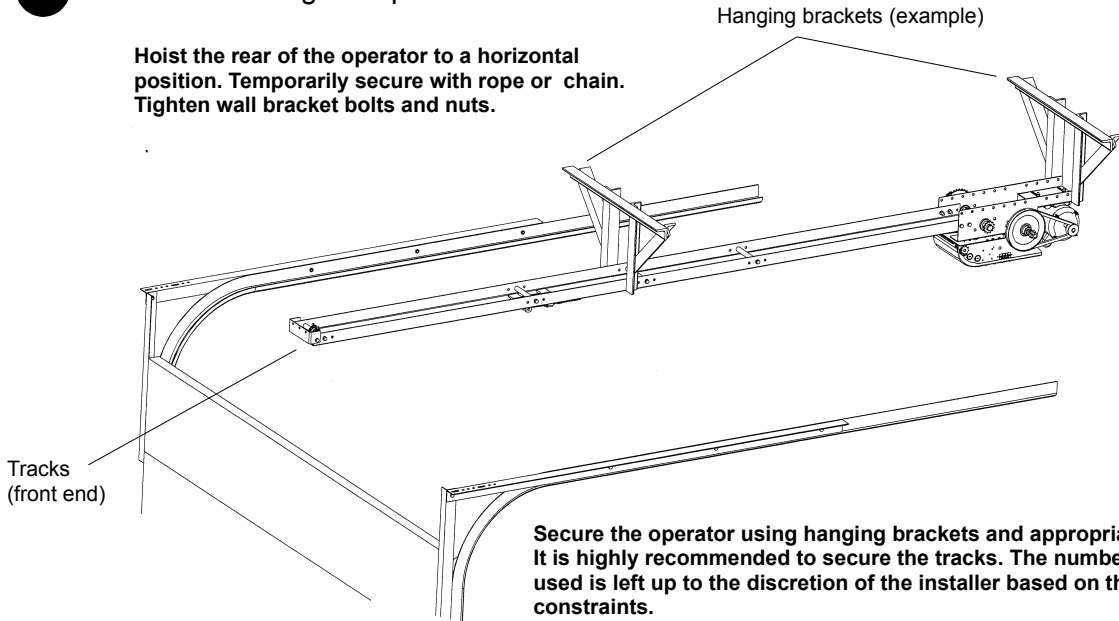

**6** Attach door arm

Attach door arm to carriage.

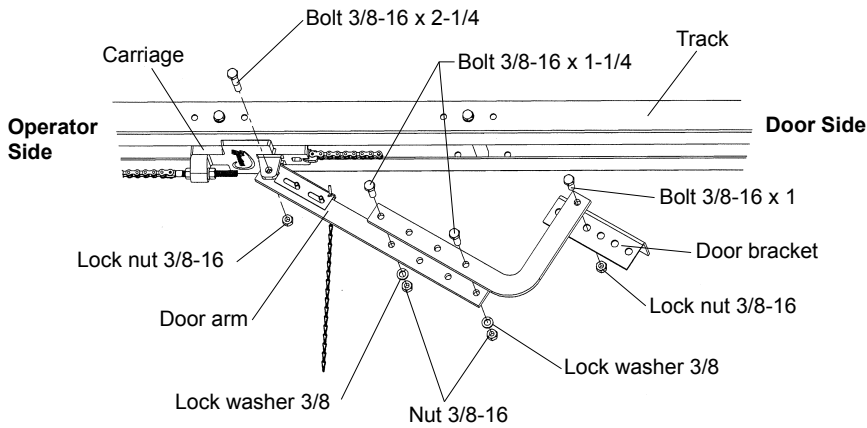

Attach door arm to door using appropriate fasteners. Mount door bracket to the center of the door.

Door arm should ideally hang vertically when the door is closed.

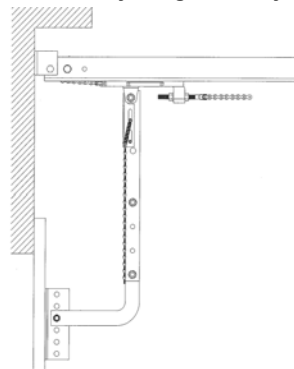
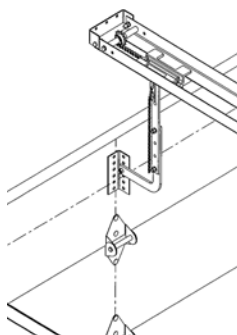

## 5 Disconnect Mechanism

### WARNING

To reduce risk of SEVERE INJURY or DEATH to persons:

- Do not stand directly under door arm when pulling the disconnect chain.
- Do not attempt to disengage the door while the operator is running.
- Do not attempt to manually force open or close a malfunctioning door.
- The door should ideally be closed when activating the disconnect mechanism.

The operator is equipped with a trolley disconnect mechanism to operate the door manually if necessary.

To manually operate the door:

1. Pull disconnect chain downwards, refer to Figure 5.
2. Disconnect trolley arm from carriage, refer to Figure 5.
3. Operate the door manually (by hand).

To return to electrical operation mode:

1. Pull on disconnect chain while reinserting the trolley arm onto the carriage.

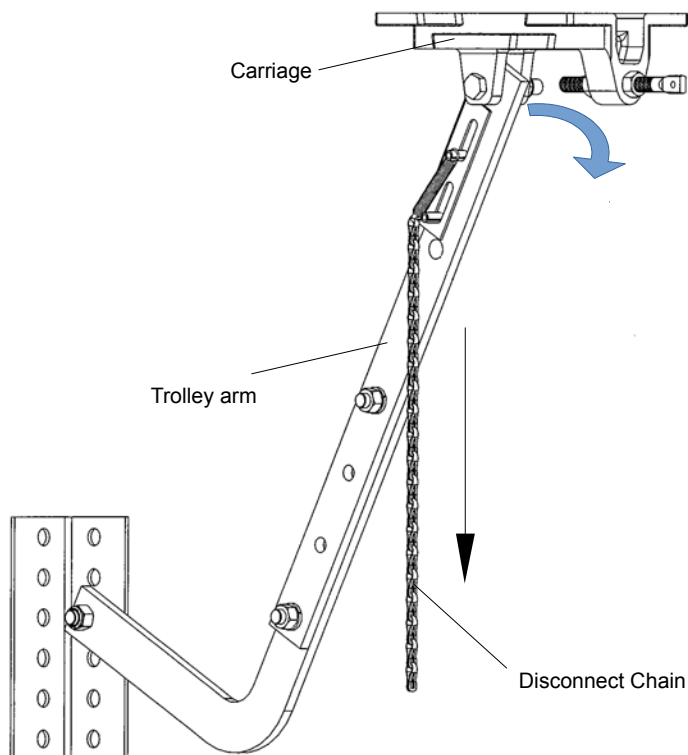

Figure 5 - Disconnect Trolley Arm From Carriage

## 6 Limit Switches & Limit Cams: Adjustment & Functionality

### WARNING

To reduce risk of SEVERE INJURY or DEATH to persons:

- Do not attempt to make limit switch adjustments unless power has been electrically disconnected.

### 6.1 Limit Switch Adjustments: Open and Close Cam Settings

This operator is equipped with the **ACCU-CAM®** feature, for precise and quick one-handed limit setting adjustments.

To adjust the limit cams, see Figure 6.

1. Pull the cam's retaining bracket back.
2. Turn the cams for limit adjustment: turning cams toward the center of the limit shaft increases door travel or turning the cams toward the limit switch decreases door travel.

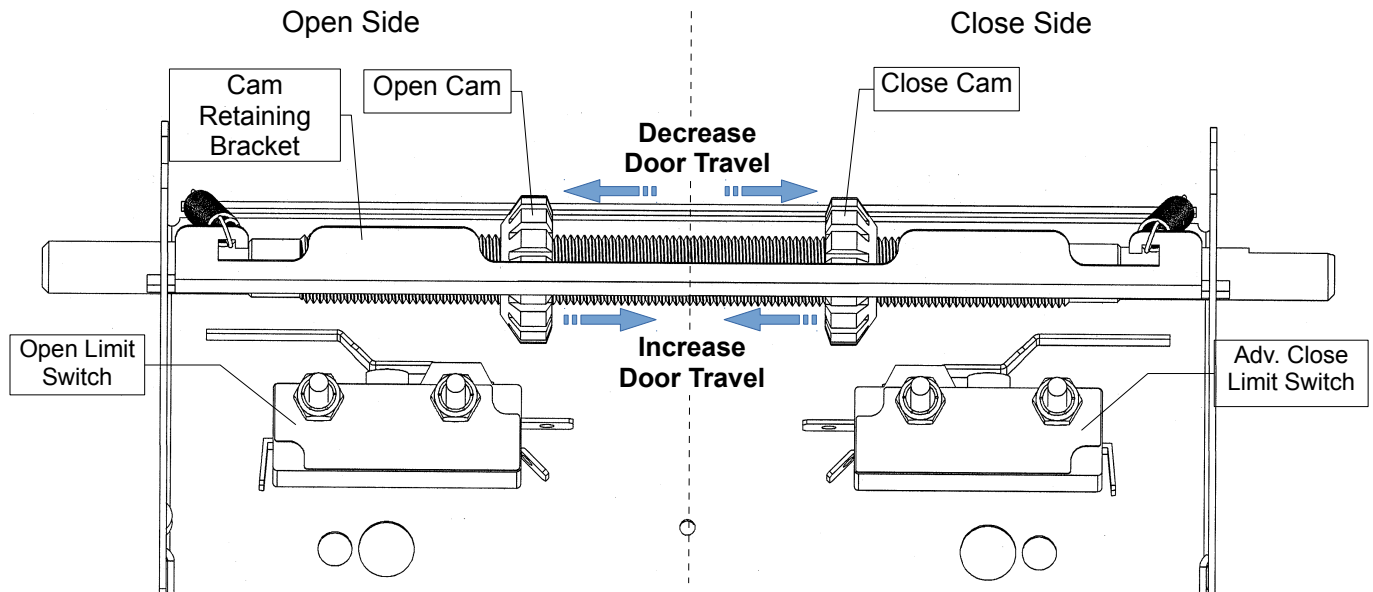

Figure 6 - Limit Cam Adjustment

### 6.2 Limit Switch Functionality

#### Open Limit Switch and Advanced Open Limit Switch

When activated, the Open Limit Switch will stop the operator while the door is travelling in the upward direction. Should be adjusted accordingly to stop door in fully open position. The microprocessor has a built-in program that replaces the Advanced Open Limit Switch.

#### Close Limit Switch and Advanced Close Limit Switch

Close Limits are not present on operators with an ECB. In its place, the microprocessor has a built-in patented Advanced Close Time feature. While the door is travelling downwards and once the Advanced Close Limit Switch is activated, the door will stop after **200 milliseconds**. The distance travelled varies according to the speed of the door. The value is fixed and cannot be re-programmed or adjusted.

## 6.3 Limit Switch Adjustment

Table 4 - Limit Switch Adjustment Procedures

Limit Switch	Adjustment Procedures
Open Limit	<ol style="list-style-type: none"> <li>1. Move the open cam close to the open limit switch and proceed as per described in section Operator Start-up, Table 9, p.29.</li> <li>2. Release cam-retaining bracket and make sure that the bracket <b>engages</b> in the slots of both cams.</li> </ol>
Advanced Close Limit	<ol style="list-style-type: none"> <li>1. Pull the disconnect chain for manual operation.</li> <li>2. <b>Manually open the door approx. 6” above the ground.</b></li> <li>3. Pull the cam-retaining bracket from the Close side, see Figure 6, and rotate Close cam manually until it activates the Close limit switch sufficiently so that a “click” can be heard.</li> <li>4. Release cam-retaining bracket and make sure that the bracket <b>engages</b> in the slots of both cams.</li> </ol>
Limit Switch Fine Adjustment	<ol style="list-style-type: none"> <li>1. Limit switch fine adjustment SHOULD be done after the main power supply is connected to the operator. Refer to section Operator Start-up, Table 9, p.29. Note: One (1) notch on cam is equal (=) to about ½” of the door travel.</li> </ol>

## 7 Electrical Wiring

### WARNING



To reduce risk of SEVERE INJURY or DEATH to persons:

- All electrical wiring should be done by a qualified professional and in accordance to local electrical codes.
- Always shut OFF the main power before performing any electrical intervention.
- Use proper wire gauge for incoming power line and for accessory connections.
- Install operator main circuit breaker next to operator for easy access for power shut-off.
- Use separate knockouts on operator control box for accessories and main power cables.
- Always separate low and high voltage wires.
- Operator should be properly grounded to the building ground and to the main power supply ground lug.
- Always use suitable and appropriate rating circuit breakers for operator protection.
- Compare available power supply voltage to voltage on operator name plate prior to electrical connection. Failure to connect appropriate power supply voltage may cause serious damage to the operator.

### NOTICE

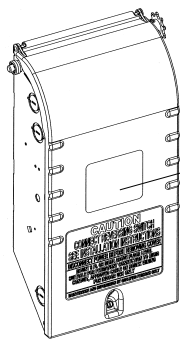
- THE OPERATOR MUST BE ADEQUATELY PROTECTED AGAINST OVERCURRENT AND SHORT-CIRCUIT.
- PLEASE REFER TO LOCAL ELECTRICAL CODE.
- PLEASE REFER TO NATIONAL ELECTRIC CODE (NFPA 70) ARTICLE 430 SECTION IV (430.51 / 430.52 / 430.53).
- PLEASE REFER TO CANADIAN ELECTRIC CODE (CSA 22.1) SECTIONS 28-200 / 28-206.



		TOLL FREE #			
		TEL: 1-800-361-2260			
		FAX: 1-888-626-0606			
		WWW.MANARAS.COM			
MODEL	<input type="text"/>	SER.#	<input type="text"/>		
HP	<input type="text"/>	VOLTS	<input type="text"/>	PH	<input type="text"/>
				AMPS	<input type="text" value="FLA"/>
CONTROL CIRCUIT	<input type="text"/>	60 Hertz		FT.LB/SEC	<input type="text"/>
DATE MFG.	<input type="text"/>			Fabriqué au Canada Made in Canada	
CAUTION DISCONNECT ELECTRIC POWER BEFORE ADJUSTING DOOR OR OPERATOR ATTENTION COUPEZ LE COURANT ÉLECTRIQUE AVANT DE METTRE AU POINT LA PORTE OU L'OPÉRATEUR					

FLA = Full Load Amp

#### Guideline to determine the branch-circuit rating of the protective device [A]:

Time Delay Fuse: 1,75 x **FLA**

Non-Time Delay Fuse: 3,0 x **FLA**

A fuse that does not exceed the next higher standard ampere rating shall be permitted.

Example: If **FLA = 3,8A**

- Time Delay Fuse:  $1,75 \times 3,8A = 6,65A \rightarrow$  Standard fuse to use: 10A
- Non-Time Delay Fuse:  $3,0 \times 3,8A = 11,4A \rightarrow$  Standard fuse to use: 15A

## NOTICE

- The installer **MUST** test for proper connection and functionality of the operator and its accessories before leaving the job site.
- The installer should also perform a demonstration for the end-user.

### 7.1 Low Voltage (Controls) and High Voltage (Power) Connections

1. Route the power line wires either from the right or from the left of the control box, as shown in Figure 7.
2. Route all low voltage control wires, as shown in Figure 7. **KEEP LOW VOLTAGE WIRES SEPARATE FROM LINE VOLTAGE WIRES.**
3. **USE COPPER CONDUCTORS ONLY.**

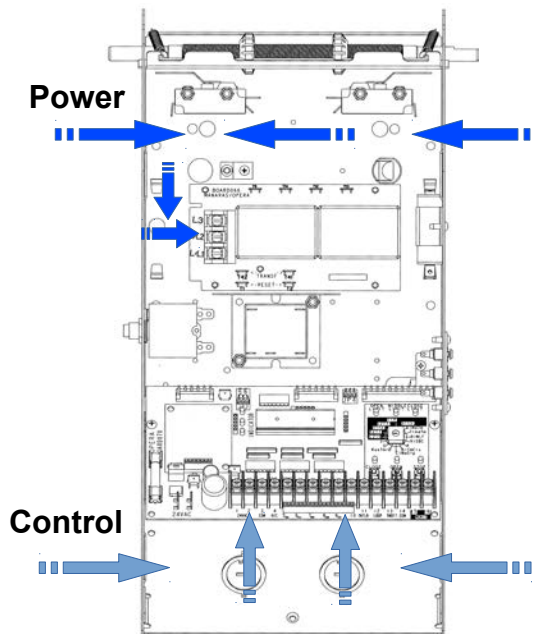
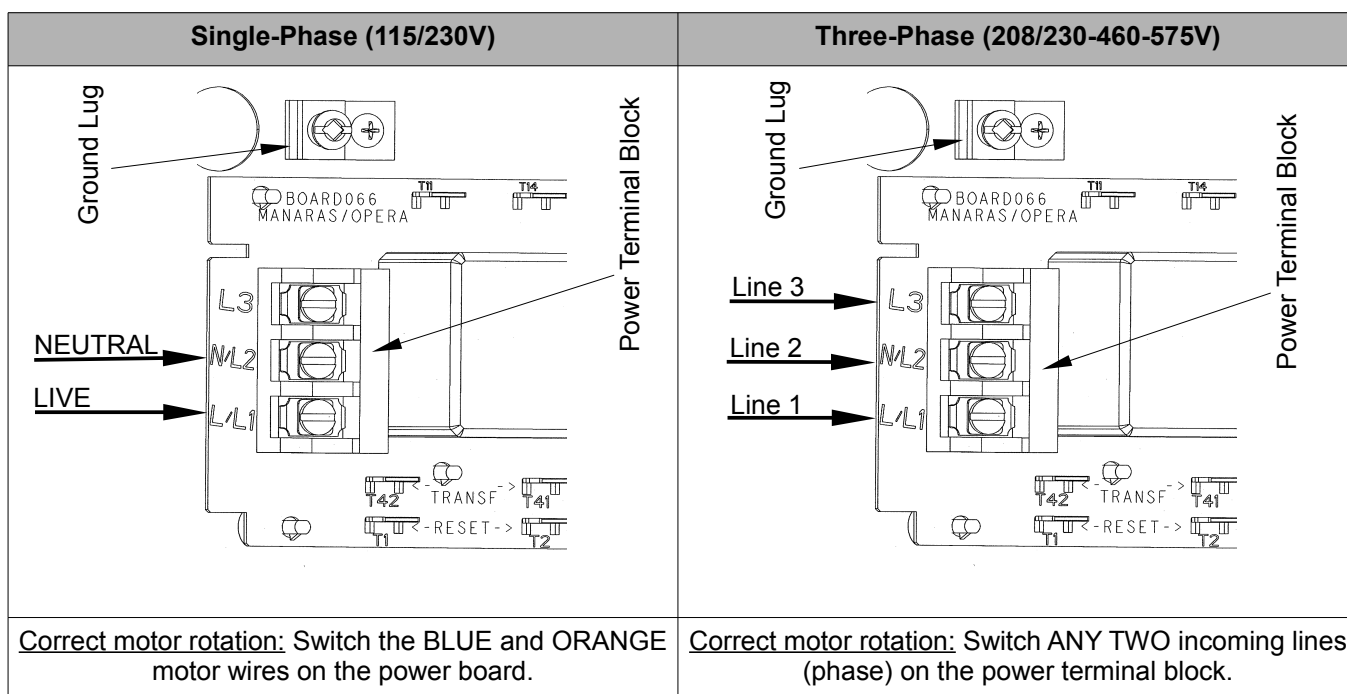

Figure 7 - Low Voltage  
(Controls) and High Voltage  
(Power) Connections

### 7.2 Main Power Supply Connection



## 7.3 Wall-Button Connection

### WARNING

- Wall controls must be mounted in clear view of the door, far enough from the door, or positioned such that the user is prevented from coming in contact with the door while operating the controls and at least 5 feet (1,5 m) above the standing surface.
- Keep low voltage wires separate from line voltage wires.
- Use copper conductors only.

#### ***Push-Button Station (PBS) Connection***

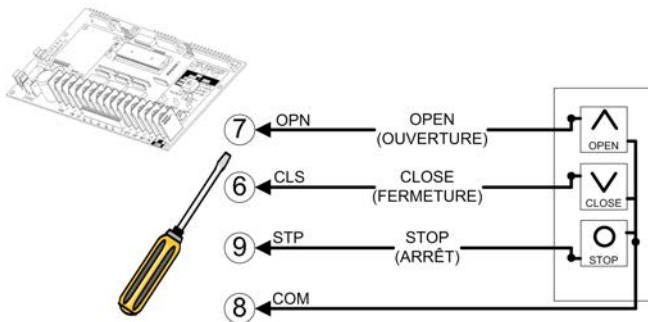

Figure 8 - STATION 020 / 084  
3-PBS Open / Close / Stop

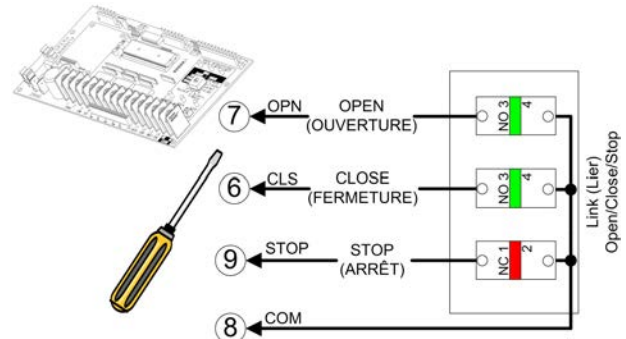

Figure 9 - STATION 041 / 049 / 056 / 076 / 078  
3-PBS Open / Close / Stop

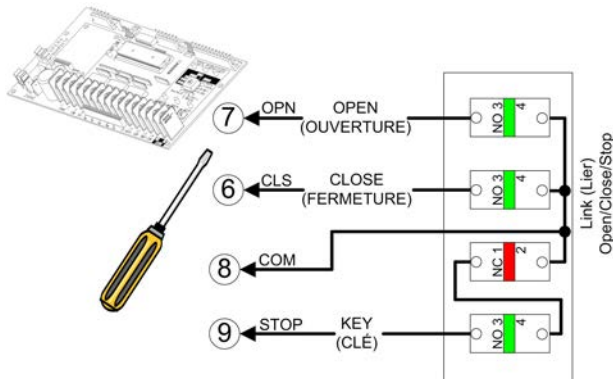

Figure 10 - STATION 079  
3-PBS Open / Close / Stop with Key Lock-out

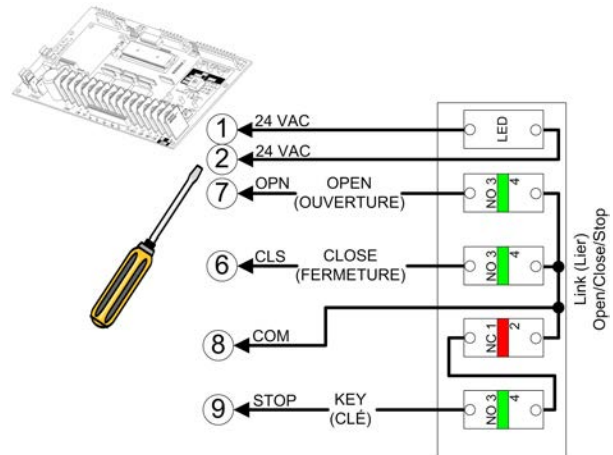

Figure 11 - STATION 080  
3-PBS Open / Close / Stop with Key Lock-out and Light

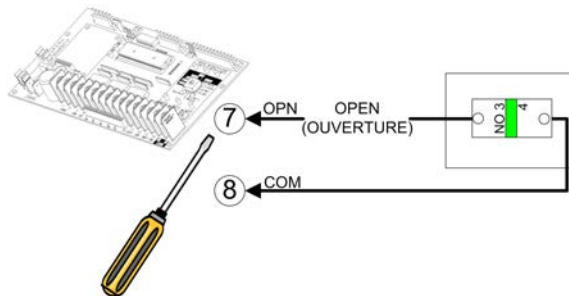

Figure 12 - STATION 001 / 081  
1-PBS Open

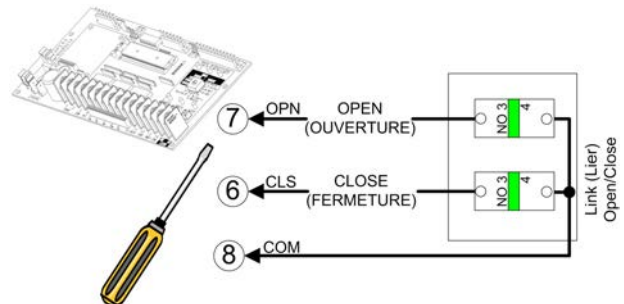

Figure 13 - STATION 010 / 082  
2-PBS Open / Close



## 7.4 Optional Accessory Connections

# NOTICE

- Photo cells must be installed facing each other across the door's path within 6" (15 cm) of the plane of the door and the beam no more than 5-3/4" (14,6 cm) above the floor.
- Keep low voltage wires separate from line voltage wires.
- Use copper conductors only.

### 7.4.1 Electric Photo Cells / Photo Eyes (Non-Monitored)

#### Through Beam Type

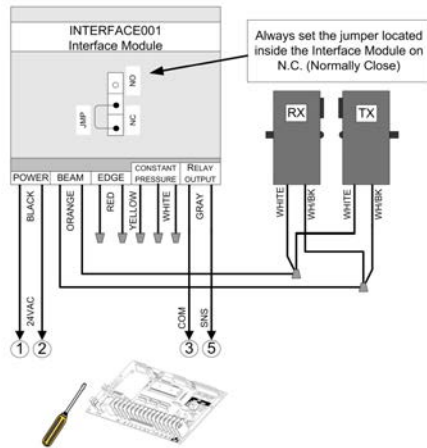

Figure 14 - PHOTO 008A/B

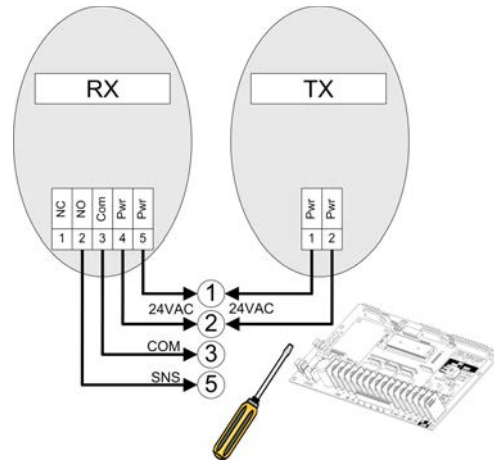

Figure 15 - PHOTO 015 / 016 / 045 / 050 / 051 / 059

#### Reflective Type

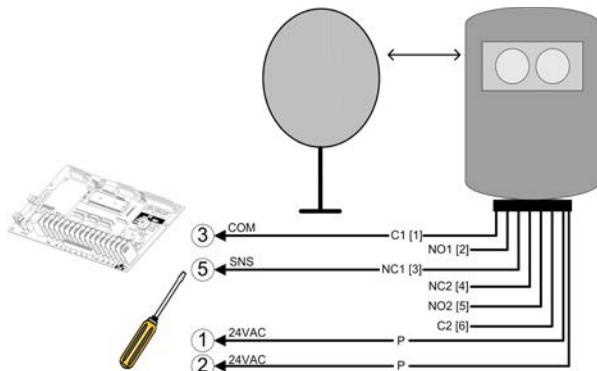

Figure 16 - PHOTO 018

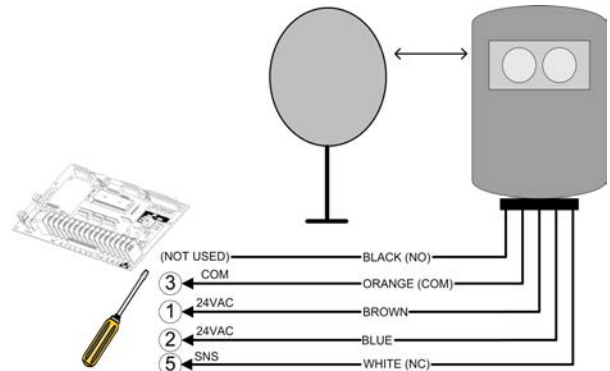

Figure 18 - PHOTO 038

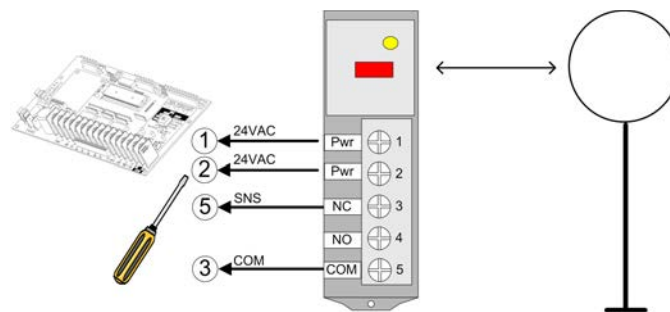

Figure 17 - PHOTO 060

## 7.4.2 Reversing Edge Device (Non-Monitored)

# NOTICE

- If the door is controlled by any device other than a constant pressure push-button station on close, including a timer-to-close, a reversing edge must be connected.

### Installation

#### **Pneumatic Sensing Edge**

1. Place the air switch in position, refer to Figure 19.
2. Place the air hose in position.
3. Use a coil cord or take-up reel to connect the air switch to the operator terminals. Install electric wires according to Figure 20 or Figure 21.
4. Connect one end of the air hose to the air switch.
5. Place the air plug in the other end of the air hose.

#### **Electric Sensing Edge**

1. Place the junction box in position, refer to Figure 19.
2. Place the sensing edge in position.
3. Use a coil cord or take-up reel to connect the sensing edge wires to the operator terminals. Install electric wires according to Figure 22.
4. Connect the sensing edge to the junction box.
5. N/A

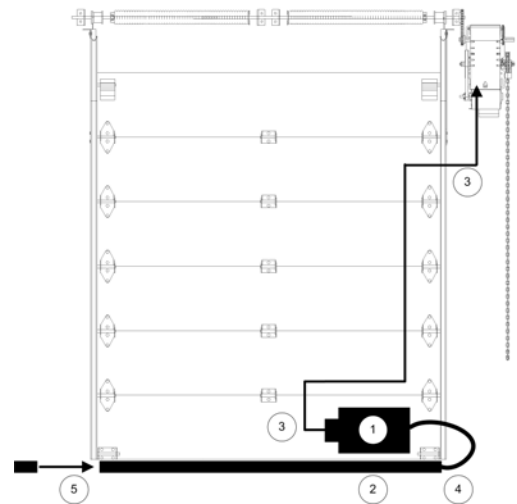

Figure 19 - Reversing Edge

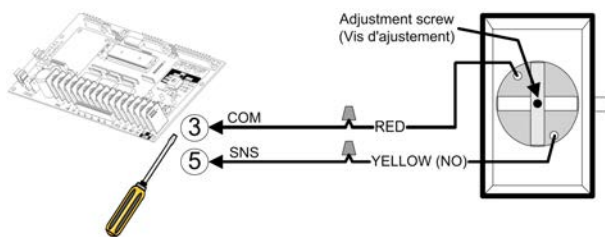

Figure 20 - AIRSWITCH 001 / 007

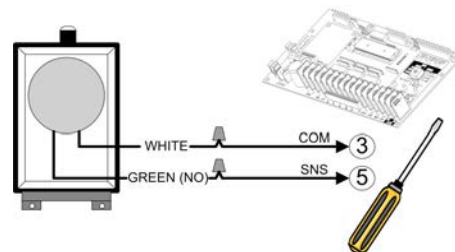

Figure 21 - AIRSWITCH 009

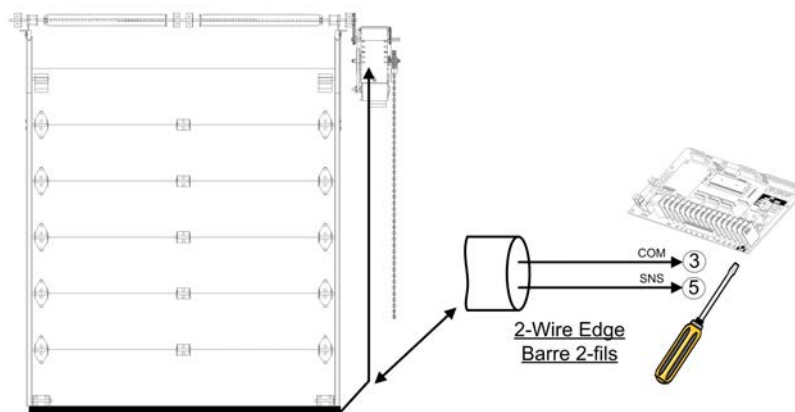

Figure 22 - Electric Reversing Edge

### 7.4.3 Pull Cord & Key Switch

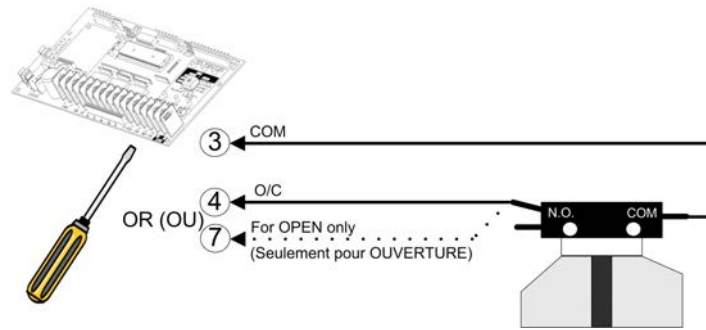

Figure 23 - PULLCORD 001 / 003 / 004 / 007

#### 2-Position Key Switch

Recommendation: Put Control Board on C2 or E2 Mode (constant-pressure-to-close)

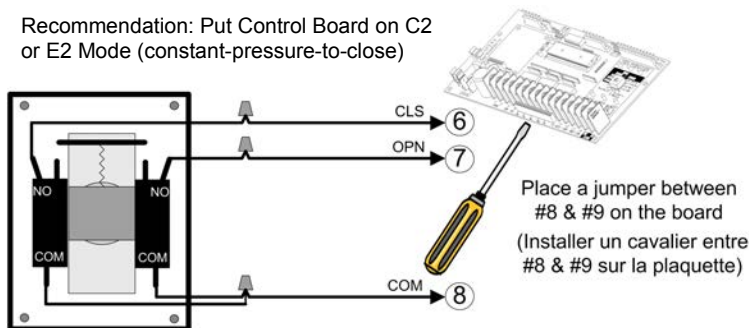

Figure 24 - KEYSWITCH 010 / 015

#### 2-Position Key Switch & Stop Button

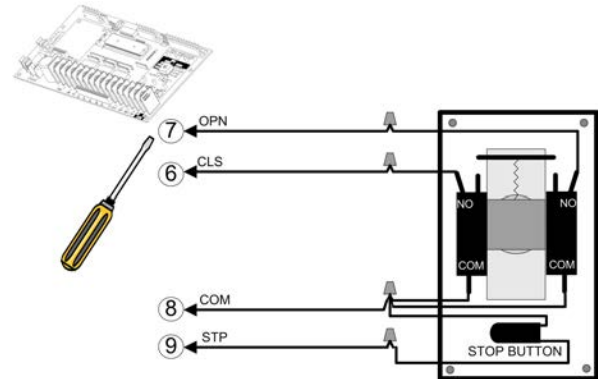

Figure 25 - KEYSWITCH 019

### 7.4.4 Vehicle Loop Detector

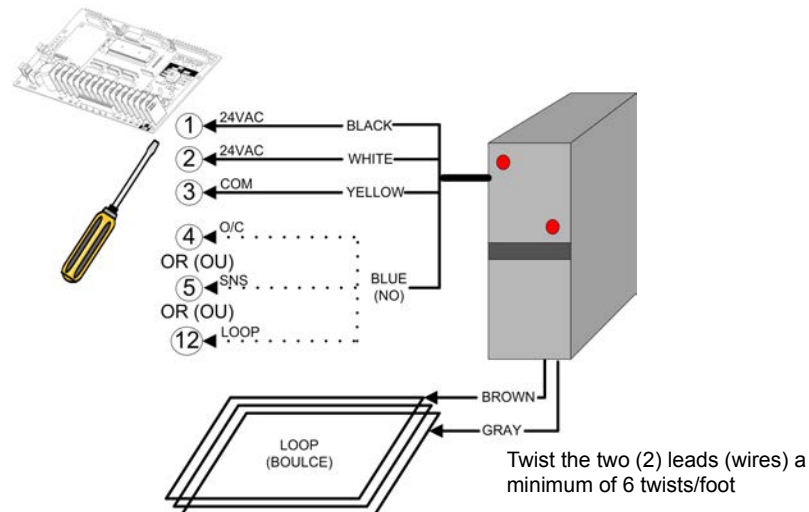

Figure 26 - Vehicle Loop Detector

### 7.4.5 Other Accessories

Additional accessories are available, such as:

- Universal Auxiliary Output Module
- External Mid-Stop Switch
- External Timer Defeat Switch

Please contact your dealer or our inside sales department at **1-800-361-2260** for further information.

# 8 Electronic Control Board (ECB) – BOARD 070E

## 8.1 General Layout

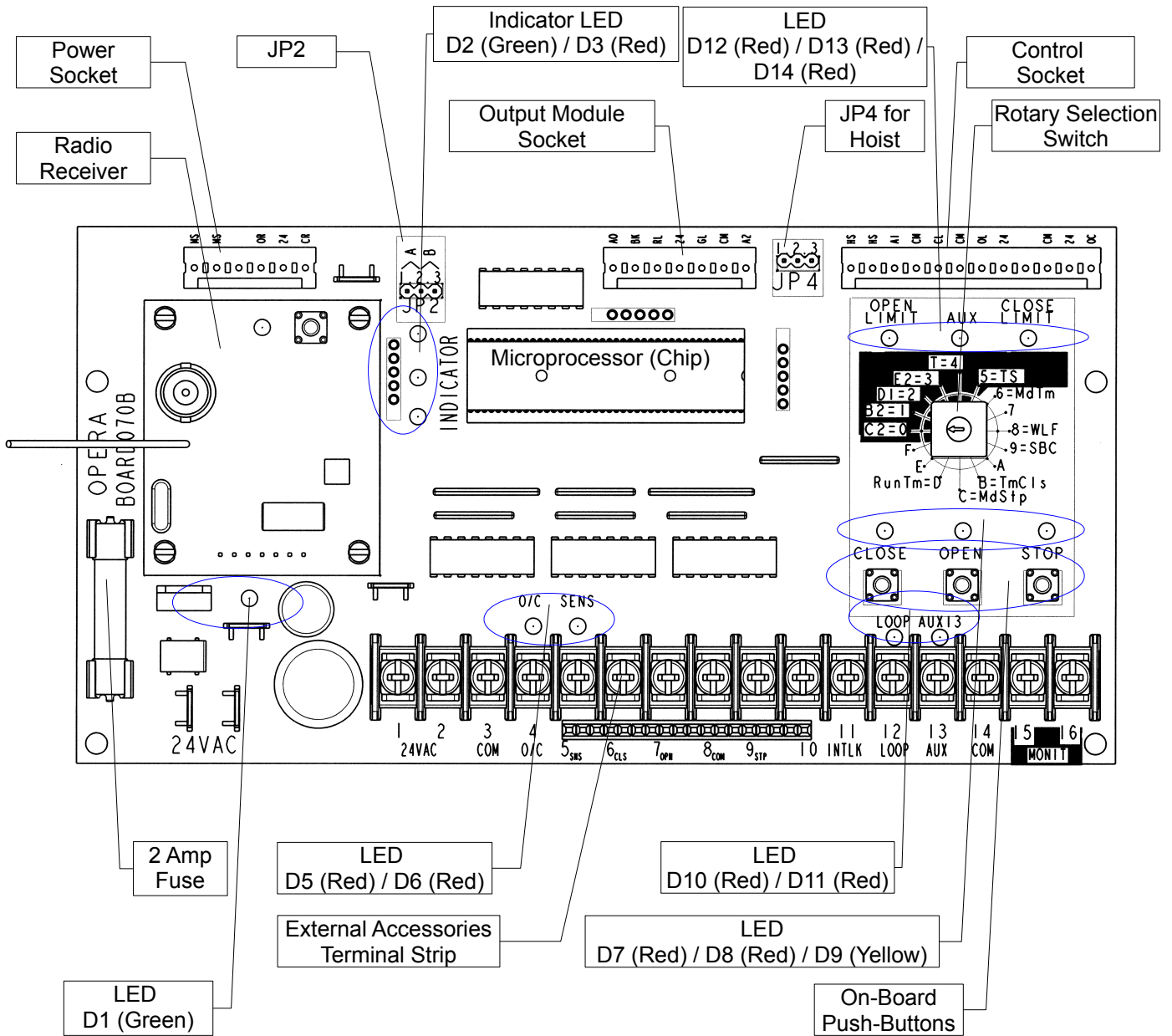













Figure 27 - Electronic Control Board – BOARD 070E

## 8.2 On-Board LED Monitoring Status

















The electronic control board's LEDs help with wiring and troubleshooting diagnostics. Every LED indicates the status of the door. BOARD 070E has a non-volatile memory and the LEDs return to their initial state after a power interruption. Refer to Figure 27, p.20 as reference.

Table 5 - LED Monitoring Status

LED	LED ON	Functions
D1	 <b>GREEN</b>	Indicates presence of 24Vdc.
D2 / D3	Refer to Table 6, p.22 as reference.	
D5	 <b>RED</b>	Only when single-button radio transmitter is activated ( <i>stays ON for +/- 1 sec</i> ).
D6	 <b>RED</b>	When reversing or sensing edge is activated.
D7	 <b>RED</b>	When close command is activated.
D8	 <b>RED</b>	When open command is activated.
D9	 <b>YELLOW</b>	Indicates that the stop button is connected and hoist or disconnect switch is not engaged.
D10	 <b>RED</b>	When inductive loop (Terminal #12) is activated ( <i>when loop is activated, door could be closed only on constant pressure</i> ).
D11	 <b>RED</b>	When external timer to close defeat switch is activated ( <i>if used</i> ).
D12	 <b>RED</b>	When open limit switch is activated.
D13	 <b>RED</b>	When external mid-stop limit switch is activated ( <i>if used</i> ).
D14	 <b>RED</b>	When close limit switch is activated.

## 8.2.1 D2 / D3 LED Monitoring Status Combination Scenarios

Table 6 - D2/D3 LED Monitoring Status - Combination Scenarios

Scenario	D2 LED GREEN	D3 LED RED	Functions
1	 OFF	 OFF	Indicates a DC power failure.
2	 OFF	 Flash	When door is closing.
3	 ON	 OFF	When operator is on standby.
4	 ON	 Flash	Indicates wrong handling feature activation ( <i>if a limit switch is not released/deactivated within 3.6 sec while door starts to close/open from the fully open/closed positions</i> ).
5	 ON	 ON	Indicates a faulty motor centrifugal switch ( <i>single-phase only</i> ).
6	 Flash	 OFF	When door is opening.
7	 Flash	 Flash	When timer to close is counting before closing the door.
8	 Flash	 Flash	When door is opening during programming of the run timer or the mid-stop features. Refer to section 8.3.2, p.24 as reference.

## 8.3 Electronic Control Board (ECB) Programming

### ⚠ WARNING

To reduce risk of SEVERE INJURY or DEATH to persons:

- Manaras-Opera strongly recommends the use of external entrapment protection devices, especially in the case of momentary contact to close (B2 wiring or Timer to Close).

### 8.3.1 Run Mode Settings

## NOTICE

- Always return the door to **fully closed position** before performing any program settings.

#### C2 Mode

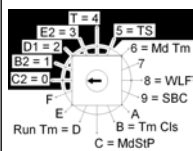

Selector switch position on **0**

#### SET SELECT SWITCH ON C2 = 0

**Function:** Momentary contact to open and stop, constant-pressure-to-close with 3-button station. Activation of entrapment protection devices will reverse the door while closing. Auxiliary devices function as an Open control and will reverse the door while closing.

#### E2 Mode

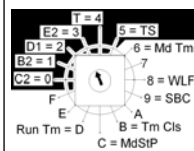

Selector switch position on **3**

#### SET SELECT SWITCH ON E2 = 3

**Function:** Momentary contact to open and constant pressure to Close. Release of Close button or activation of entrapment protection devices will reverse the door to fully open position.

#### B2 Mode

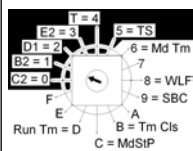

Selector switch position on **1**

#### SET SELECT SWITCH ON B2 = 1

**Function:** Momentary contact to Open, Close and Stop with 3-button station. Activation of entrapment protection devices will reverse the door during closing. Auxiliary devices function as an Open-Close controls and will reverse the door while closing.

#### T Mode

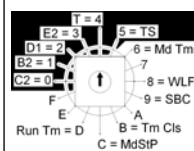

Selector switch position on **4**

#### SET SELECT SWITCH ON T = 4

**Function:** Under Mode T=4, if entrapment protection devices are activated while door is closing, the door will reverse and will not close by Timer to Close (TTC). TTC will also be disabled if the chain hoist is engaged or if the stop is activated before elapsed time. TTC will resume its normal operation only after the door is fully closed.

#### D1 Mode

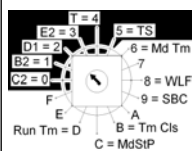

Selector switch position on **2**

#### SET SELECT SWITCH ON D1 = 2

**Function:** Constant-pressure-to-open and constant-pressure-to-close. Activation of entrapment protection devices will stop the door while closing.

#### TS Mode

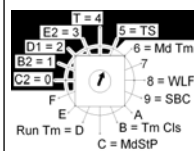

Selector switch position on **5**

#### SET SELECT SWITCH ON TS = 5

**Function:** Under Mode TS=5, if entrapment protection devices are activated while door is closing, the door will reverse and will close by Timer to Close (TTC). TTC will also be refreshed if the chain hoist is engaged, if the stop is activated before elapsed time or in the case of a power outage.

**T (4) & TS (5) Mode: Only applicable with Timer to Close, refer to Features Programming section, p. 24.**

### 8.3.2 Features Programming

## NOTICE

- Always return the door to **fully closed position** before performing any program settings.

#### Maximum Run Timer

Maximum run timer is set to 90 seconds by default. When programmed, this feature calculates the total time required for the door to travel from the fully closed to the fully opened position and adds 10 seconds to this time. Therefore, if the door is obstructed while travelling up or down, this feature will stop the operator after the maximum run timer time has elapsed.

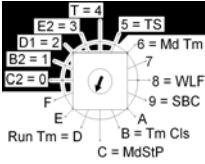
Run Timer Programming	Select Switch	Set Run Timer to Default
<ol style="list-style-type: none"> <li>Verify if the close limit switch is activated and if the close LED is ON.</li> <li>Set select switch on <b>D = Run Tm</b>.</li> <li>Press the “Open” button and let the door reach the fully opened position. <b>Result: 10 sec</b> is added to the total travel time.</li> <li>Set select switch on run mode <b>(0, 1, 2, 3, 4 or 5)</b>.</li> </ol>		<ol style="list-style-type: none"> <li>Verify if the close limit switch is activated and if the close LED is ON.</li> <li>Set select switch on <b>D = Run Tm</b>.</li> <li>Press the “Stop” button. <b>Result:</b> The max. run timer is set to the default value of <b>90 sec</b>.</li> <li>Set select switch on run mode <b>(0, 1, 2, 3, 4 or 5)</b>.</li> </ol>

#### Timer to Close (TTC)

Timer to Close (T = 4 or TS = 5 Mode), will close the door from the fully opened and mid-stop positions after a factory preset time (5 sec.). Timer to Close can be programmed in increments of 1 sec. or 15 sec.

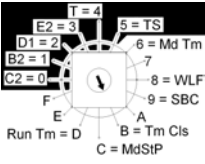
TTC Programming	Select Switch	TTC Deactivation
<ol style="list-style-type: none"> <li>Verify if the close limit switch is activated and if the close LED is ON.</li> <li>Set select switch on <b>B = Tm Cls</b>.</li> <li>Press the “Stop” button to return the time to <b>0 sec.</b> or to reprogram.</li> <li>Press the “Open” button to add 15 sec. increments, or press the “Close” button to add 1 sec. increments. Max. 4 min.</li> <li>Set select switch on <b>T = 4 or TS = 5</b>. Refer to Run Mode Settings section, p. 23 for mode descriptions.</li> </ol>		<ol style="list-style-type: none"> <li>If the TTC is not required, set select switch on run mode <b>(0, 1, 2, or 3)</b>.</li> </ol>

#### Timer to Close User Suspension Feature

This feature allows the Timer to Close to be enabled/disabled from the floor by using a wall push-button station. This feature allows the user to keep the door opened for ONE CYCLE only.

TTC Deactivation	TTC Activation
While the door is in the closed position, by pressing the “Stop” button 3 times and the “Close” button 3 times consecutively on the push-button station, the TTC is deactivated ( <i>TTC is suspended</i> ).	The TTC is re-activated ( <i>TTC returns to normal function</i> ) when the door is closed.



**Mid-Stop (MD STP)****NOTICE**

- The Mid-Stop position must always be programmed/adjusted so that there is a minimum gap of 12” between the top of the tallest vehicle and the bottom edge of the door.

Mid-Stop, when activated, will allow the door to stop at a predetermined position when an open signal is given from the fully closed position. The Radio control or Close push-button will close the door from the mid-stop position. The door will open fully from mid-stop position if the Open button is activated.

Mid-Stop Activation	Select Switch	Mid-Stop Deactivation
<ol style="list-style-type: none"> <li>1. Verify if the close limit switch is activated and if the close LED is ON.</li> <li>2. Set select switch on <b>C = MdStP</b>.</li> <li>3. Press the “Open” button. While the door is moving press the “Stop” button at the desired (mid-stop) position.</li> <li>4. Set select switch on run mode <b>(0, 1, 4, or 5)</b>.</li> </ol>		<ol style="list-style-type: none"> <li>1. Verify if the close limit switch is activated and if the close LED is ON.</li> <li>2. Set select switch on <b>C = MdStP</b>.</li> <li>3. Press the “Stop”, “Close” and “Open” buttons consecutively.</li> <li>4. Set select switch on run mode <b>(0, 1, 2, 3, 4 or 5)</b>.</li> </ol>

**Mid-Stop Timer (MD TM)**

This feature allows the Timer to Close to be enabled/disabled at the Mid-Stop position.

MD TM Activation	Select Switch	MD TM Deactivation
<ol style="list-style-type: none"> <li>1. Verify if the close limit switch is activated and if the close LED is ON.</li> <li>2. Set select switch on <b>6 = Md Tm</b>.</li> <li>3. Press the “Close” button.</li> <li>4. Set select switch on run mode <b>(4, or 5)</b>.</li> </ol>		<ol style="list-style-type: none"> <li>1. Verify if the close limit switch is activated and if the close LED is ON.</li> <li>2. Set select switch on <b>6 = Md Tm</b>.</li> <li>3. Press the “Stop” button.</li> <li>4. Set select switch on run mode <b>(0, 1, 2, 3, 4 or 5)</b>.</li> </ol>

**Single-Button Control (SBC)**

With this feature, it is possible to use a single-channel transmitter for a Commercial Application, as well as a Single-Button Control (SBC). The SBC provides the user with the possibility to open, stop or close the door by using a single-button radio transmitter (or a single push-button station).

SBC Activation	Select Switch	SBC Deactivation
<ol style="list-style-type: none"> <li>1. Verify if the close limit switch is activated and if the close LED is ON.</li> <li>2. Set select switch on <b>9 = SBC</b>.</li> <li>3. Press the “Open” button.</li> <li>4. Set select switch on run mode <b>(1, 4, or 5)</b>.</li> </ol>		<ol style="list-style-type: none"> <li>1. Verify if the close limit switch is activated and if the close LED is ON.</li> <li>2. Set select switch on <b>9 = SBC</b>.</li> <li>3. Press the “Stop” button.</li> <li>4. Set select switch on run mode <b>(0, 1, 2, 3, 4 or 5)</b>.</li> </ol>

**Universal Auxiliary Output Module (8 = WLF)**

The universal auxiliary output module is sold separately. The module allows for the connection of external devices such as: red and green warning lights (custom sequences available, ask Manaras-Opera for details), air curtains, horns, locks, etc... Call your dealer or Manaras-Opera for further information.

Please contact your dealer or our inside sales department at **1-800-361-2260** for further information.

## 9 On-Board Radio Receiver

The On-Board Radio Receiver is factory installed on all operators equipped with an Electronic Control Board **BOARD 070** and features Rolling Code Technology.

### 9.1 Radio Receiver Components and Compatible Transmitting Devices

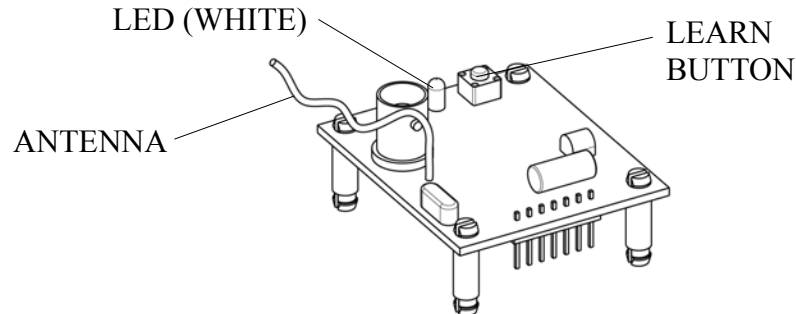

Each Receiver is compatible with the devices listed below:

**Note:** You can match 3-Button Transmitters AND 1-Button Transmitters with the same Receiver. Mix and match accordingly for your application (ordered separately). One receiver will accept up to 50 Transmitters.

- **RADIOEM 101:** 1-Button Opera Brand Transmitter for operation of a Single Door. Can be configured as a traditional commercial sequence or as a Single Button Control (The SBC provides the user with the possibility to open/stop/close the door by using a single-button radio transmitter (or a single push-button station).
- **RADIOEM 103 SD:** 3-Button Opera Brand Transmitter for operation of a Single-Door (open/stop/close function) (field selectable).
- **RADIOEM 103 MD:** 3-Button Opera Brand Transmitter for operation of Multiple-Doors (open function) (field selectable).
- **KEYLESS 042:** Wireless Entry Transmitter for keyless access to a Single or Multiple-Doors.
- Other soon to be offered Opera Brand devices; 3-button mini key-chain transmitter, multi-channel receiver, etc...

### 9.2 Programming Instructions

Radio Receiver Programming Instructions	
To MATCH a Transmitter to the Receiver	To DELETE ALL Transmitters from the Receiver memory
1.HOLD the Receiver's <b>LEARN</b> button until the LED flashes (approx. 2 sec.) (frequency of 1 sec. ON / 1 sec. OFF). 2.HOLD any button on the Transmitter until the Receiver's LED stops flashing.	1.HOLD the Receiver's <b>LEARN</b> button until the LED flashes (approx. 10 sec.) (frequency of 1/3 sec. ON / 1/3 sec. OFF).

### 9.3 Radio Control Functions – 1 and 3-Button Transmitters

Table 7 - Radio Control Functions - 1-Button Transmitter RADIOEM101

Transmitter	Modes	Functions	Programming (On operator's ECB)
 1-Button Transmitter <b>RADIOEM101</b>	Commercial Sequence - 1-Button	OPEN / CLOSE → Button  <b>Door is CLOSED:</b> - Click Button → Door OPENS FULLY <b>During UPWARD Travel:</b> - Click Button → Nothing happens <b>Door is OPENED:</b> - Click Button → Door CLOSES FULLY <b>During DOWNWARD Travel:</b> - Click Button → Door reverses and OPENS FULLY <b>Door is STOPPED:</b> - Not possible in this mode. Door is either FULLY OPENED or FULLY CLOSED.	Standard default mode.  1. Door is in fully CLOSED position. 2. On ECB, verify if the close limit switch is activated (CLOSE LED is ON). 3. On ECB, set select switch on <b>9 = SBC</b> . 4. On ECB, press “ <b>STOP</b> ” button. 5. On ECB, select run mode ( <b>1, 4, or 5</b> ).
	Single Button Control (SBC)  Available with the Electronic Control Board (ECB) only.  Alternating Sequence	OPEN / STOP / CLOSE → Button  <b>Door is CLOSED:</b> - Click Button → Door OPENS <b>During UPWARD Travel:</b> - Click Button → Door STOPS <b>Door is STOPPED:</b> - Click Button → Door CLOSES <b>During DOWNWARD Travel:</b> - Click Button → Door STOPS <b>Door is STOPPED:</b> - Click Button → Door OPENS  <b>Note:</b> If the door is STOPPED for more than 2 minutes, the next movement will be UPWARD regardless of the previous movement.	1. Door is in fully CLOSED position. 2. On ECB, verify if the close limit switch is activated (CLOSE LED is ON). 3. On ECB, set select switch on <b>9 = SBC</b> . 4. On ECB, press “ <b>OPEN</b> ” button. 5. On ECB, select run mode ( <b>1, 4, or 5</b> ).

Table 8 - Radio Control Functions – 3-Button Transmitter RADIOEM103SD/MD

Transmitter	Modes	Functions	Programming
	Three Button Transmitter	1.OPEN → Small Button 2.CLOSE → Medium Button 3.STOP → Large Button	1.Unscrew the screw on the back of the Transmitter. 2.Insert a flat screwdriver in the rounded corner of the Transmitter. 3.Pry open the Transmitter's cover. 4.Position jumper on <b>SD</b> (Single Door). 5.Put the Transmitter's cover back-on and fasten the screw. 6.On ECB, select run mode <b>(1, 4, or 5)</b> .
3-Button Transmitter  <b>RADIOEM 103SD/MD</b>	3 x 1-Button	1.DOOR #1 → Small Button 2.DOOR #2 → Medium Button 3.DOOR #3 → Large Button  Each button acts separately as a 1-Button Transmitter (Commercial Sequence or SBC depends on operator settings).	1.Unscrew the screw on the back of the Transmitter. 2.Insert a flat screwdriver in the rounded corner of the Transmitter. 3.Pry open the Transmitter's cover. 4.Position jumper on <b>MD</b> (Multiple Doors). 5.Put the Transmitter's cover back-on and fasten the screw. 6.On ECB, select run mode <b>(1, 4, or 5)</b> .

## 10 Operator Start-up

### **WARNING**

To reduce risk of SEVERE INJURY or DEATH to persons:

- Personnel should keep away from a door in motion and keep the moving door in sight until it is completely closed or opened. NO ONE SHOULD CROSS THE PATH OF A MOVING DOOR.
- Never go under a stopped, partially opened door.

1. Turn power ON.
2. Use on-board, wall-button station (Open/Close/Stop), external entrapment device or jumper wires for testing, see Table 9.

Table 9 - Start-up and Testing Guide

Test	Door Position	Action	Door Response	LED Status
Open	Door at 6" from the closed position	<ol style="list-style-type: none"> <li>1. Press "OPEN".</li> <li>2. Check if door is stopped by Open limit switch.</li> <li>3. If required, re-adjust Open limit, as shown in Figure 6, p.12.</li> </ol>	Door should open instantly.	"Open Limit" LED is ON
Close	Door at fully open position	<ol style="list-style-type: none"> <li>1. Press "CLOSE".</li> <li>2. Check if door is stopped by Close limit switch.</li> <li>3. If required, re-adjust Close limit, as shown in Figure 6, p.12.</li> </ol>	<p>- <b>C2 mode:</b> (selector switch on C2=0). Door should close as long as the close button is activated.</p> <p>- <b>B2 mode:</b> (selector switch on B2=1). Door should close instantly.</p>	"Close Limit" LED is ON
Sense Edge	A) Door at fully closed position	Activate external entrapment device OR	Door should stay at closed position.	"SENS" LED is ON as long as the contact is maintained
	B) Door is closing (movement)	Momentarily touch #3 & #5 on the main terminal with a jumper wire.	Door should stop and then reverse to fully opened position.	
Open & Close (single-button radio)	A) Door at fully opened position	Activate the single-button transmitter OR	Door should close.	"O/C" LED is ON as long as the contact is maintained (+/- 2 sec)
	B) Door at fully closed position	Momentarily touch #3 & #4 on the main terminal with a jumper wire.	Door should open.	
	C) Door is closing (movement)		Door should reverse to fully opened position.	

## 11 Clutch Adjustment

### NOTICE

- The friction clutch is NOT intended to protect people. It is designed to protect the operator and door system against potential damage.
- The friction clutch is factory adjusted during final testing. Proper adjustments should be done on site according to the door characteristics and application.

**Best Practices Encouraged by Manaras-Opera**  
 Manaras-Opera recommends the installation of a hard stop at the end of the tracks (ex. bolt, deformation of tracks, bumper spring, pusher spring, etc). With such installation, the door is prevented from running out of the tracks. The clutch (torque limiter) will prevent any damage to occur to the door system.

This operator is supplied with a **Door Lock Sensor feature**. The door lock sensor feature prevents the door from getting damaged when the door lock hasn't been removed prior to electronic operation. It eliminates the need of expensive external interlock wiring.

This feature can only be used on operators equipped with a friction clutch. When the lock stops the door, the clutch slips and in less than 1 second, the door will reverse a fraction of a second to release the tension on the lock.

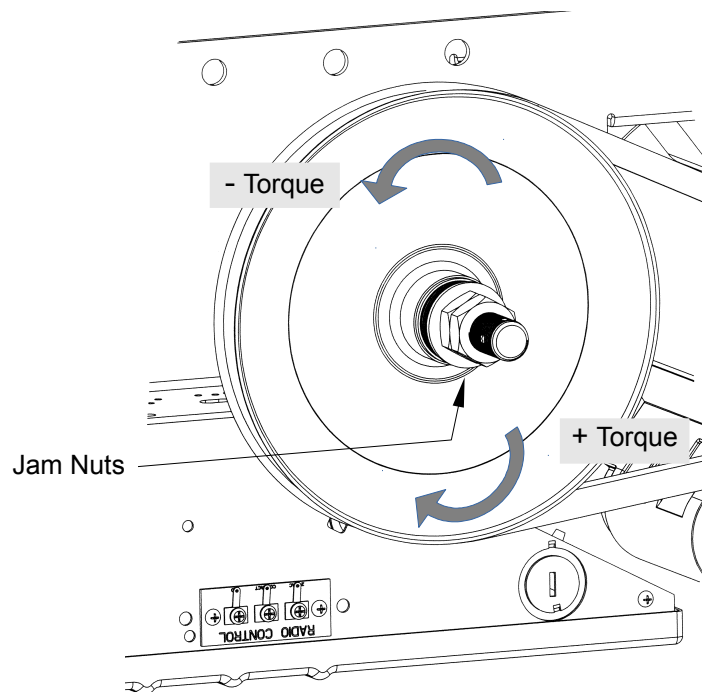

Figure 28 - Clutch Adjustment

To adjust the clutch:

1. Unlock the jam nuts with two (2) 7/8" keys, refer to Figure 28.
2. Rotate the nut counter-clockwise to release the tension.
3. Gradually rotate the nut clockwise until there is just enough tension to permit smooth operation (while still allowing the clutch to slip if the door is obstructed).
4. Lock the jam nuts.

## **User Instructions**

# **IMPORTANT SAFETY INSTRUCTIONS**

### **WARNING**

## **TO REDUCE THE RISK OF SEVERE INJURY OR DEATH TO PERSONS:**

1. READ AND FOLLOW ALL INSTRUCTIONS.
2. Never let children operate or play with door controls. Keep the remote control (where provided) away from children.
3. Personnel should keep away from a door in motion and keep the moving door in sight until it is completely closed or opened. **NO ONE SHOULD CROSS THE PATH OF A MOVING DOOR.**
4. Test the door's safety features at least once a month. After adjusting either the force or the limit of travel, retest the door operator's safety features. Failure to adjust the operator properly may cause severe injury or death.
5. For products having a manual release, if possible, use the manual release only when the door is closed. Use caution when using this release with the door open. Weak or broken springs may cause the door to fall rapidly, causing severe injury or death.
6. **KEEP DOORS PROPERLY OPERATING AND BALANCED.** See Door Manufacturer's Owner Manual. An improperly operating or balanced door could cause severe injury or death. Have trained door systems technician make repairs to cables, spring assemblies and other hardware.
7. **SAVE THESE INSTRUCTIONS.**

### **IMPORTANT**

For more information or for immediate assistance, please contact your local dealer.

### **NOTICE**

- The installer should perform a demonstration of the operator and its accessories (ex: push-button station, radio control), external entrapment protection device and manual release for the end-user.

For instructions regarding the Manual Release, refer to the Installation Instructions found in section 5, p.11.

# 1 Quick Fix Instructions

Table 10 - Basic Troubleshooting Guide ~ from floor level

Symptom	Possible Cause	Fix Problem
Door doesn't respond to any command	<ul style="list-style-type: none"> <li>◆ "Stop" button is stuck. (LED D9 is OFF)</li> <li>◆ No power supply. (LED D2 is OFF)</li> </ul>	<ul style="list-style-type: none"> <li>➔ Press and release the "Stop" button on the wall station several times.</li> <li>➔ Verify the incoming power line from the main breaker, making sure it has not tripped or blown a fuse.</li> </ul>
Door doesn't not respond to "Close" or radio commands	<ul style="list-style-type: none"> <li>◆ Photo cells are not properly aligned or are obstructed.</li> <li>◆ Loop is obstructed (presence of metal). (LED D10 is ON)</li> </ul>	<ul style="list-style-type: none"> <li>➔ Clear the obstruction or re-align photo cells.</li> <li>➔ Clear the obstruction.</li> </ul>
When pressing "Open" button, door opens ~1-2 ft, then stops and reverses	<ul style="list-style-type: none"> <li>◆ Mechanical door lock is engaged.</li> <li>◆ Verify if the rubber seal at the bottom of the door is frozen to the ground (winter time).</li> </ul>	<ul style="list-style-type: none"> <li>➔ Release the door lock.</li> <li>➔ Clear ice and free the rubber seal at the bottom of the door.</li> </ul>
Door doesn't respond to any radio command	<ul style="list-style-type: none"> <li>◆ No power supply. (transmitter light is OFF)</li> <li>◆ Poor radio control range.</li> <li>◆ Photo cells are not properly aligned or are obstructed.</li> </ul>	<ul style="list-style-type: none"> <li>➔ Replace transmitter's battery.</li> <li>➔ Bring the radio transmitter closer to the operator.</li> <li>➔ Clear the obstruction or re-align photo cells.</li> </ul>
Timer to Close doesn't close the door	<ul style="list-style-type: none"> <li>◆ Timer to Close has been suspended accidentally for ONE cycle.</li> </ul>	<ul style="list-style-type: none"> <li>➔ Timer to Close will return to normal after the door has been fully closed. Refer to p.24 for further details.</li> </ul>
Timer to Close closes the door after being suspended	<ul style="list-style-type: none"> <li>◆ Timer to Close has been reactivated accidentally.</li> </ul>	<ul style="list-style-type: none"> <li>➔ To suspend the Timer to Close, close the door completely. Then press the "Stop" button 3 times and then press the "Close" button 3 times. Refer to p.24 for further details.</li> </ul>



## **Maintenance Instructions**

# IMPORTANT SAFETY INSTRUCTIONS

### **WARNING**

## TO REDUCE THE RISK OF SEVERE INJURY OR DEATH TO PERSONS:

- Inspections, service and repairs should be performed anytime a malfunction is observed or suspected.
- Only qualified persons should perform maintenance on a door operator and all safety precautions should be taken into consideration.
- When servicing, always disconnect operator from main power supply.
- **KEEP DOORS PROPERLY OPERATED AND BALANCED.**
- See Door Manufacturer's Owner Manual. An improperly operated or balanced door can cause severe injury or death. Have qualified door system technicians perform repairs to cables, spring assemblies and other hardware.

## **1 Preventative Maintenance Schedule**

### **1.1 Mechanical Inspection**

The door area should always be kept clear of dirt, rocks or any other substances in order to insure proper operation. Maintenance of the door operator should be performed according to the schedule in Table 11 and Table 12.

*Table 11 - Mechanical Inspection Schedule (Part 1)*

Time Frame	Inspection
<b>Every Month</b>	<ul style="list-style-type: none"> <li>• Test the door's safety features.</li> <li>• Verify the brake function (if applicable).</li> <li>• After adjusting either the clutch or the limit's travel, retest the operator's safety features.</li> <li>• Verify gear reducer's oil level (if applicable).</li> </ul>
<b>Every 3 Months</b>	<ul style="list-style-type: none"> <li>• Verify and adjust the clutch if necessary.</li> </ul>
<b>Every 6 Months</b>	<ul style="list-style-type: none"> <li>• Lubricate all moving parts. Bushings are oil impregnated and are lubricated for life.</li> <li>• Verify that all mechanical parts function properly.</li> <li>• Inspect the V-belt and adjust or replace if necessary.</li> <li>• Manually operate the door. If the door does not open or close freely, correct the cause of the malfunction.</li> </ul>

Table 12 - Mechanical Inspection Schedule (Part 2)

Time Frame	Inspection
<b>Once a Year</b>	<ul style="list-style-type: none"> <li>• Run the operator a few cycles:               <ul style="list-style-type: none"> <li>◦ Make sure that the door rollers are rolling smoothly on the track.</li> <li>◦ Listen to the motor: The motor should hum quietly and smoothly.</li> <li>◦ Verify that the limits operate quietly and smoothly: investigate any unusual noise.</li> </ul> </li> <li>• Verify that the mounting bolts are holding the unit securely.</li> <li>• Inspect the unit for evidence of corrosion.</li> <li>• Change the gear reducer's oil, at the very least, after every <b>2500 hours</b> of operation or once a year (if applicable).</li> </ul>

## 1.2 Electrical Inspection

It is recommended that the electrical maintenance inspections be performed at the same intervals as the mechanical maintenance inspections.

Table 13 - Electrical Inspection

Time Frame	Inspection
<b>Every Month</b>	<ul style="list-style-type: none"> <li>• Inspect the unit for evidence of corrosion on electrical wires and connectors.</li> <li>• Inspect the wiring compartment and remove any dirt from the control units.</li> <li>• Verify all the grounding wires and terminals for corrosion. Be particularly careful to verify the ground wires.</li> <li>• Verify the terminal strips to insure that all the screws are tightened.</li> <li>• Verify that the pneumatic edge or other entrapment protection devices installed on the operator are fully operational.</li> <li>• Verify the voltage at the input terminals while the operator is running. The voltage must not drop more than 10% momentarily. If the voltage drop is too deep when running, the relays may chatter and the contact points will wear prematurely and may eventually seize. Verify the power terminals for corrosion.</li> <li>• Verify the current consumption of the unit with an amp-meter. The current value should be consistent with the nameplate specifications. Investigate any anomaly.</li> </ul>

## 1.3 Band Brake Maintenance

### WARNING

To reduce the risk of SEVERE INJURY or DEATH to persons:

- Be sure that the main power is OFF before performing any changes on the operator.

### 1.3.1 Changing a Brake Band

The brake band is preformed at the factory. Please insert the brake band carefully around the brake drum.

#### 1 Remove solenoid cover

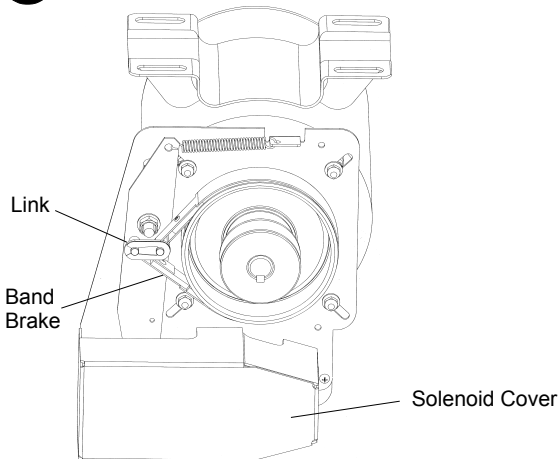

#### 2 Remove link and used band brake

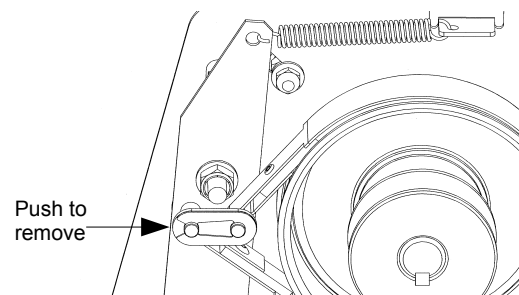

#### 3 Replace band brake

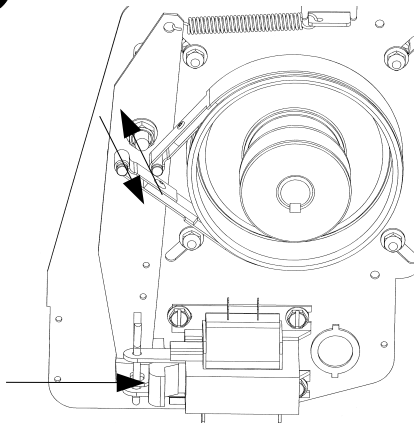

Push solenoid plunger to reduce tension when removing or installing the band brake.

#### 4 Place the link

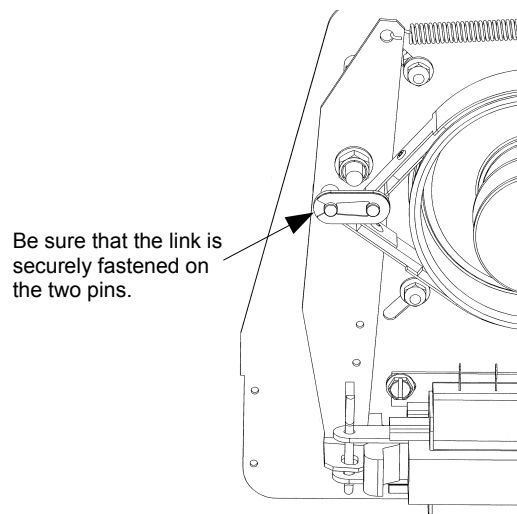

#### 5 See brake adjustment on next page

## 1.3.2 Brake Adjustment

The brake is factory set, however, after extensive use the brake may need to be adjusted.

### 1 Remove solenoid cover

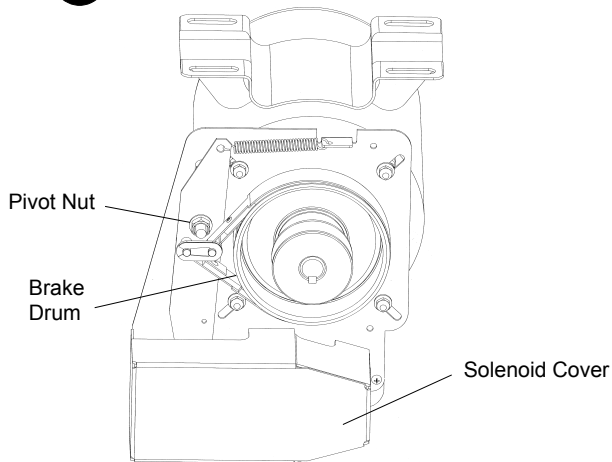

### 2 Loosen pivot nut

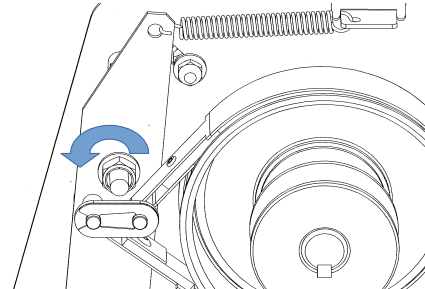

### 3 Adjust solenoid gap

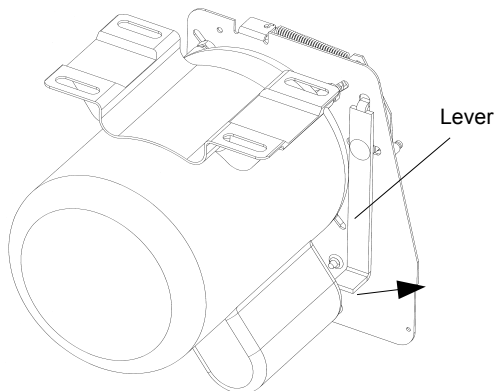

Pull the lever to adjust the gap between the plunger and solenoid body.

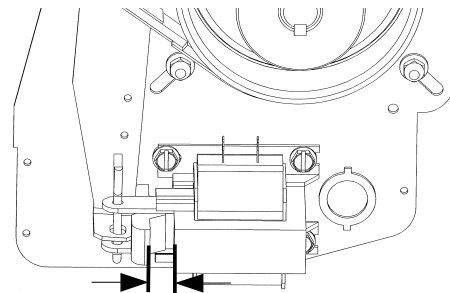

Gap must be between 1/4" and 3/8".

### 4 Tighten pivot nut

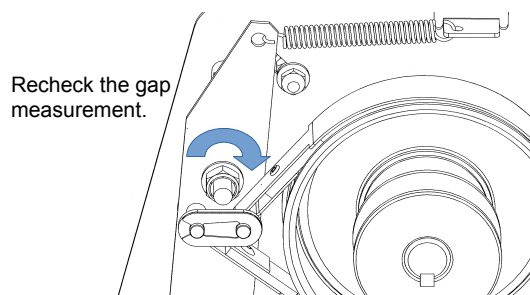

### 5 Check brake adjustment

Manually push the plunger onto the solenoid body, and verify that the brake drum rotates easily by hand.

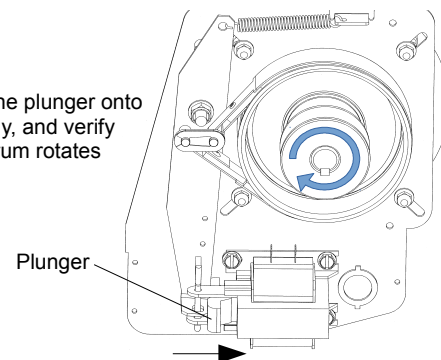

### 6 Re-install solenoid cover

## 1.4 Drum Brake Adjustment (Premium Apartment Trolley or BRAKE014/015)

The brake is factory set, however, after extensive use the brake may need to be adjusted.

### 1 Remove solenoid cover

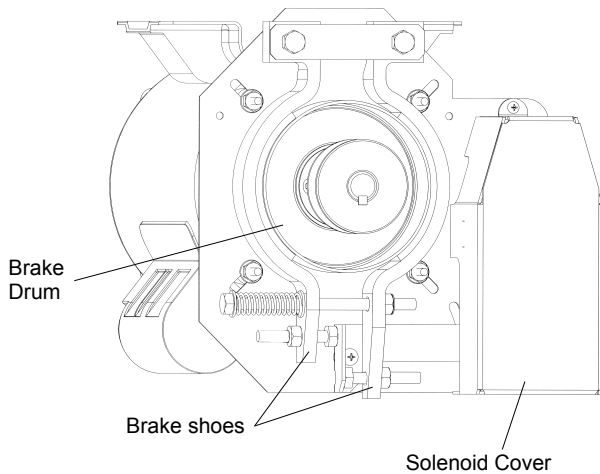

### 2 Adjust solenoid gap

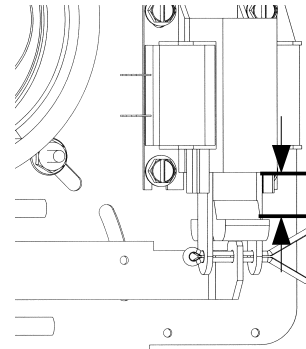

Gap must be between 1/4" and 3/8".

### 3 Adjust the right and left holding bolt

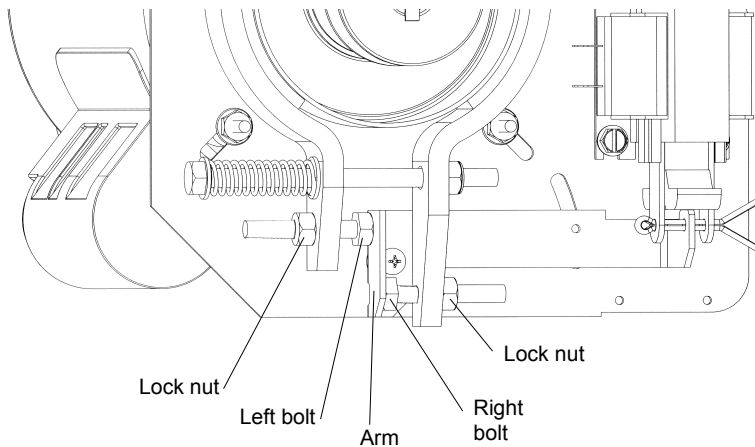

- Set the proper gap on the solenoid and hold it with one hand.
- Adjust the right holding bolt until it touches the arm.
- Adjust the left holding bolt until it touches the arm.
- Manually push the plunger onto the solenoid body, and verify the gap between the brake shoes and the brake drum. If the gap is not the same on both side re-adjust the brake.
- Tighten the lock nut.

### 4 Check brake adjustment

Manually push the plunger onto the solenoid body, and verify that the brake drum rotates easily by hand.

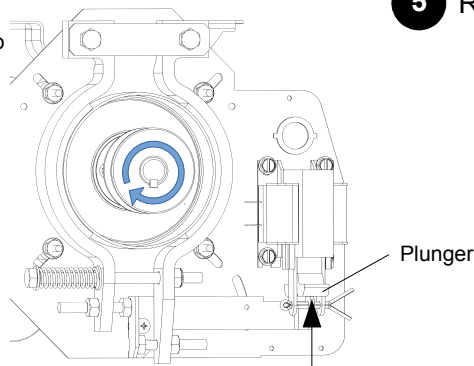

### 5 Re-install solenoid cover

## 2 Troubleshooting Guide

The electronic control board LEDs help with wiring and troubleshooting diagnostics. Every LED indicates the status of the door. The electronic control board has a non-volatile memory and the LEDs return to their initial state after a power interruption.

**Easy Fix:** Before starting any intervention, verify the LED's monitoring status and refer to Table 5, p.21 for a proper diagnosis.

Table 14 - Troubleshooting Guide - Part 1

Symptom	Probable Cause	Suggested Action
Door doesn't respond to any command	<ul style="list-style-type: none"> <li>◆ "Stop" button is stuck. (LED D9 is OFF)</li> <li>◆ Control station is not connected or is wired incorrectly. (LED D9 is OFF)</li> <li>◆ No power supply. (LED D2 is OFF)</li> </ul>	<ul style="list-style-type: none"> <li>➔ Press and release any "Stop" button.</li> <li>➔ Verify and correct wiring.</li> <li>➔ Verify the incoming power line from the main breaker, making sure it has not tripped or blown a fuse.</li> </ul>
Operator is not operating as expected	<ul style="list-style-type: none"> <li>◆ Selector switch is not set on the desired mode.</li> </ul>	<ul style="list-style-type: none"> <li>➔ Set switch on desired mode, refer to p.23 for further details.</li> </ul>
Timer to Close doesn't close the door	<ul style="list-style-type: none"> <li>◆ Timer to Close has been suspended accidentally for ONE cycle.</li> </ul>	<ul style="list-style-type: none"> <li>➔ Timer to Close will return to normal after the door has been fully closed. Refer to p.24 for further details.</li> </ul>
Door doesn't respond to any radio command	<ul style="list-style-type: none"> <li>◆ No power supply. (Transmitter light is OFF)</li> <li>◆ Transmitter is not properly programmed.</li> <li>◆ Photo cells are not properly aligned or are obstructed.</li> </ul>	<ul style="list-style-type: none"> <li>➔ Replace the transmitter's battery.</li> <li>➔ Reprogram transmitter.</li> <li>➔ Clear the obstruction or re-align photo cells.</li> </ul>
Door doesn't respond to "Open" command, but does respond to "Close" command	<ul style="list-style-type: none"> <li>◆ Defective "Open" push-button or "Open" limit switch.</li> <li>◆ Loose wire on "Open" push-button or "Open" limit switch.</li> </ul>	<ul style="list-style-type: none"> <li>➔ Replace push-button or limit switch.</li> <li>➔ Verify and correct wiring.</li> </ul>
Door doesn't respond to "Close" command, but does respond to "Open" command	<ul style="list-style-type: none"> <li>◆ Defective "Close" push-button or "Close" limit switch.</li> <li>◆ Loose wire on "Close" push-button or "Close" limit switch.</li> </ul>	<ul style="list-style-type: none"> <li>➔ Replace push-button or limit switch.</li> <li>➔ Verify and correct wiring.</li> </ul>

Table 15 - Troubleshooting Guide - Part 2

Symptom	Probable Cause	Suggested Action
<b>“Stop” button doesn’t stop the door</b>	◆ Two 3-push button stations (or more) are connected in parallel.	→ Verify and correct wiring (Stop buttons in series, only Open & Close in parallel).
<b>Door reverses to fully open position after the door closes and reaches the floor</b>	◆ The “Close” limit switch is not being engaged by travelling cam. ◆ An “Open” command is being given.	→ The “Close” limit switch needs to be adjusted properly at the end of travel. → Verify “Open” push-button or any opening device for short-circuit.
<b>Door doesn’t open or close, motor hums or blows the main breaker</b>	◆ Mechanical door lock is engaged. ◆ Door is jammed. ◆ Brake doesn’t release, if applicable. ◆ Loose wire on solenoid brake, if applicable. ◆ Faulty solenoid brake, if applicable.	→ Release the door lock. → Verify manual operation of door. → Verify and adjust brake tension. → Verify and correct wiring. → Replace.
<b>Motor hums when “Open” or “Close” buttons are pressed</b>	◆ Loose motor wires. ◆ Defective capacitor.	→ Verify and correct wiring. → Replace.
<b>Motor fails to shut off at fully closed or fully opened positions</b>	◆ Defective limit switch. ◆ Limit cams are not adjusted. ◆ Limit drive chain is broken. ◆ Loose sprocket on limit shaft. ◆ Limit shaft does not rotate.	→ Operate limit switch manually while door is moving. If door does not stop, replace the switch. → Verify and adjust. → Replace. → Tighten set screw. → Verify and replace accordingly.
<b>Motor turns but door does not move</b>	◆ Sprocket key is missing. ◆ Drive chain is broken. ◆ Clutch is slipping.	→ Replace. → Replace. → Adjust clutch to proper tension.
<b>Limit switches do not hold their settings</b>	◆ Loose drive or limit chain. ◆ Limit cam retaining bracket is not engaging in the slots of the limit cams. ◆ Limit cams are binding on shaft threads. ◆ Limit shaft has a slight “play”.	→ Adjust chain to proper tension. → Be sure it is engaged in slots of both cams. → Lubricate shaft threads. Limit cams should turn freely. → Verify and adjust.
<b>Poor radio range</b>	◆ Transmitter battery is low. ◆ Radio antenna is not properly positioned. ◆ Ambient radio, environmental or building structure interference.	→ Verify and replace battery. → Make sure antenna cable is not bent. Cable should be passed through control box. → Check connection of plug-in antenna. If required, add an external antenna (socket on receiver available).

### 3 Electrical Drawings

#### 3.1 1 Phase Operator with BOARD 070E

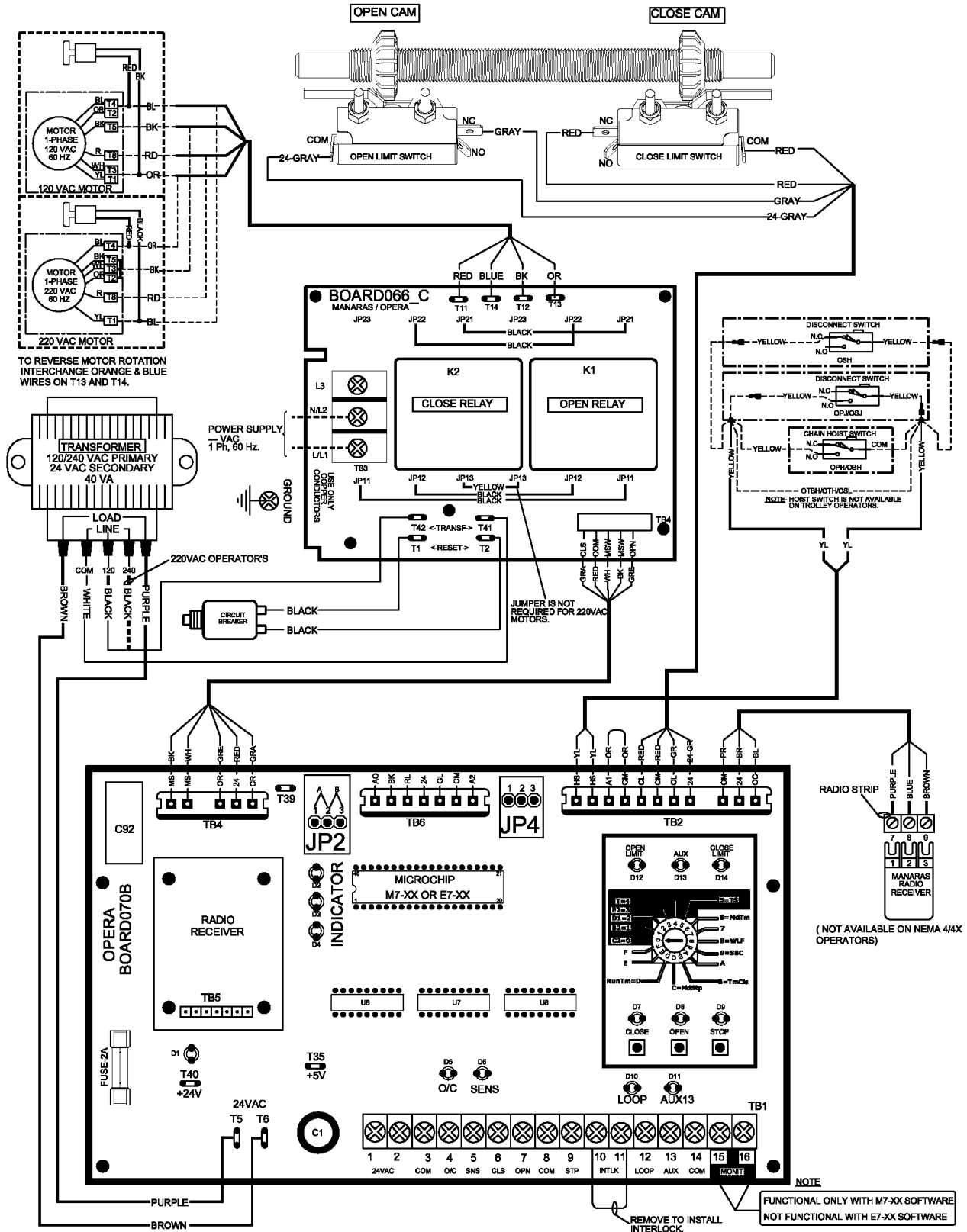

Figure 29 - EDWG1107006601



### 3.2 3 Phase Operator with BOARD 070E

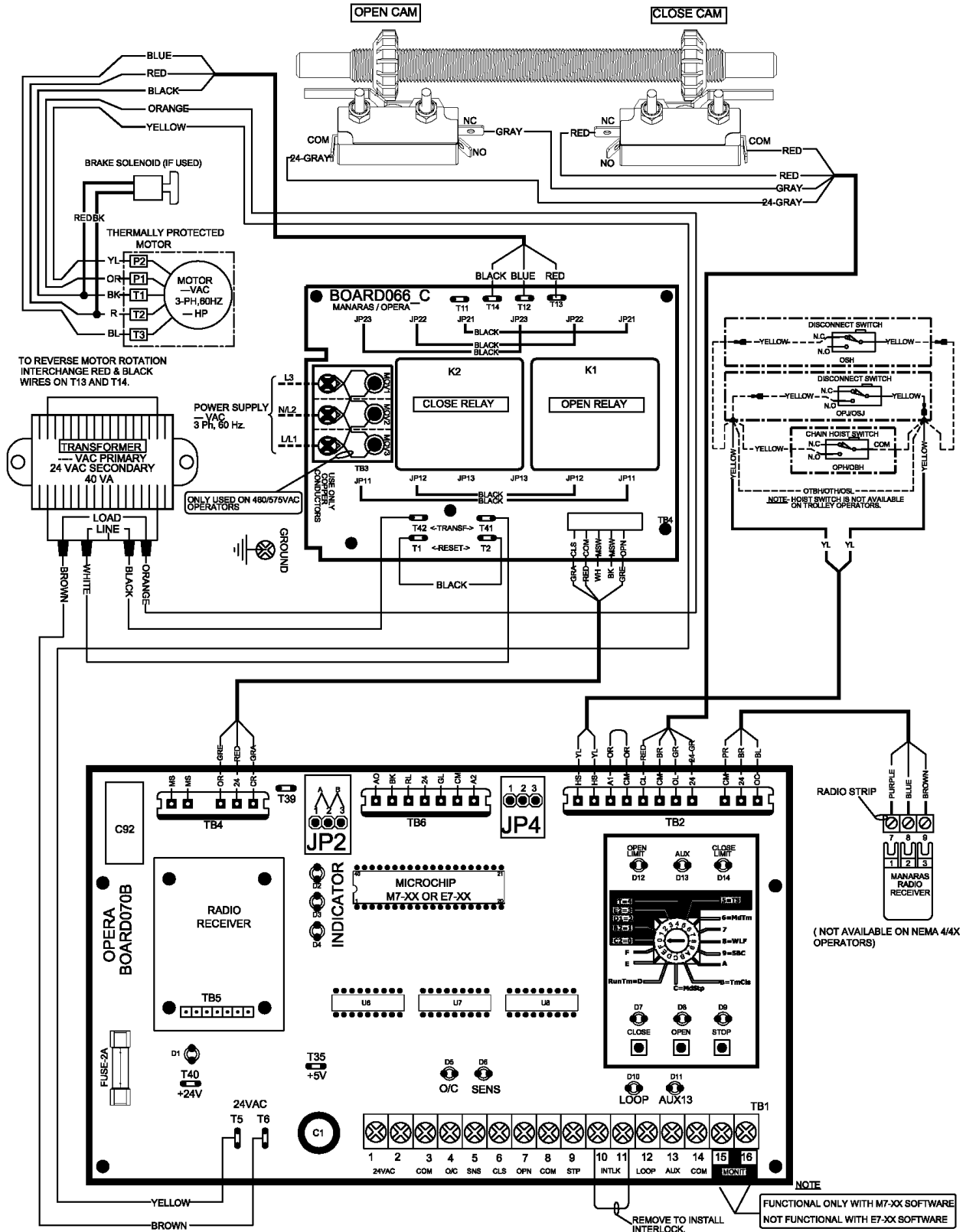

Figure 30 - EDWG1307006601

### 3.3 External Wiring with BOARD 070E

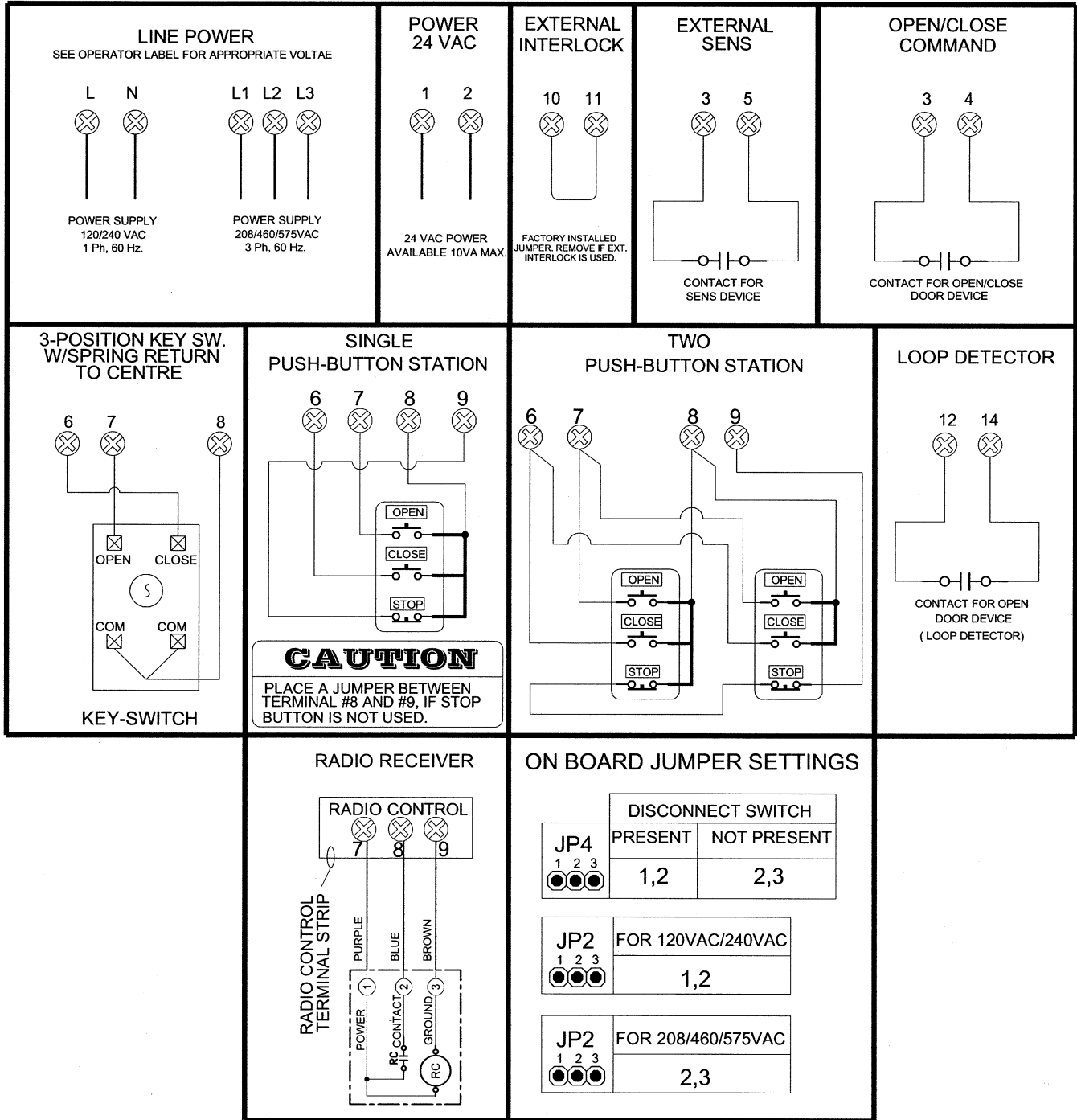

Figure 31 - External Wiring

## 4 Mechanical Exploded Views and Replacement Components

### 4.1 OTH / OTBH

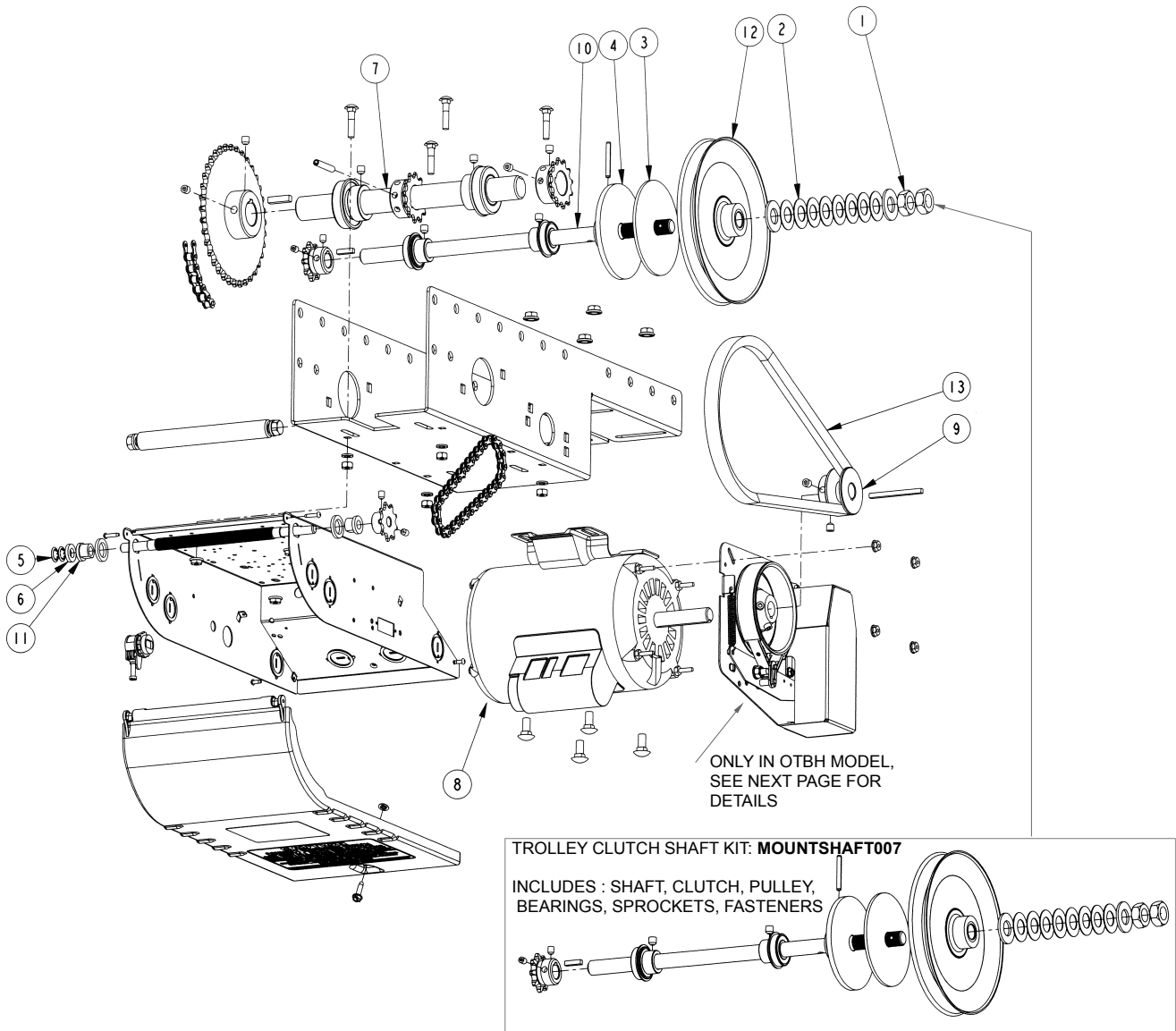

Figure 32 - OTH / OTBH Mechanical Exploded View

Table 16 - OTH / OTBH Replacement Components

No	Qty	Description	Manaras-Opera Part #	No	Qty	Description	Manaras-Opera Part #
1	2	5/8-24 HEX JAM NUT ZP	NUT015	8	1	MOTOR	SEE Table 19
2	8	BELLEVILLE WASHER (31.5X16.3X0.8)	WASHER035	9	1	MOTOR PULLEY 2.0 x 5/8 5L STL	PULLEY014
3	1	CL.PAD 5/8x4x0.125"	CLUTCHPAD005	10	1	MTBH INPUT SHAFT 5/8-24X14-3/4	SHAFT080
4	1	CLUTCHPLATE 5/8	CLUTCHPLATE004	11	2	OPERA LIMIT SHAFT BUHING	BUSHING055
5	2	EXTERNAL 3/8 RETAINING RING	CLIP021	12	1	PULLEY 7" x 5/8" 5L/B	PULLEY020
6	1	FLT WASHER 3/8 (.391 x .750 x .130) ZP	WASHER064	13	1	TYBE B, INSIDE LENGHT 30	VBELTB30
7	1	MDJ, MGT, MSJ, MTH, MTBH DRIVE	SHAFT048				

## 4.2 OTBH Brake

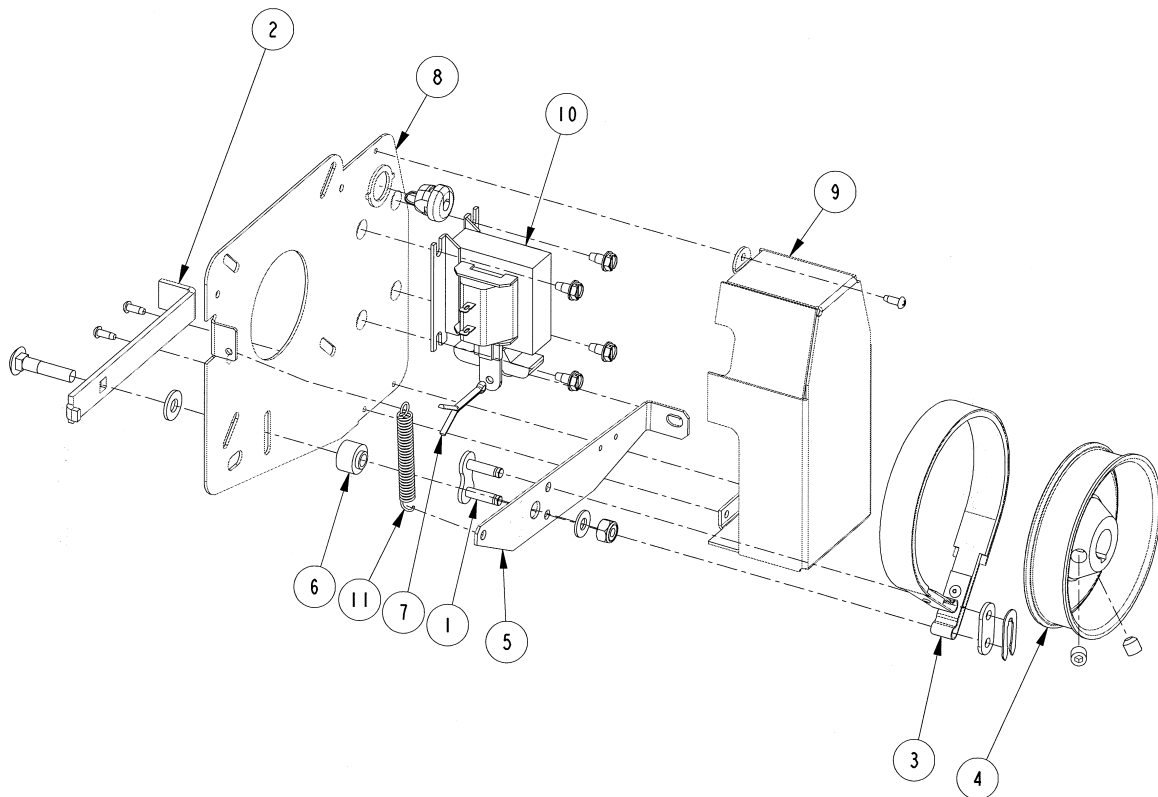

Figure 33 - BRAKE 011 Mechanical Exploded View

Table 17 - BRAKE 011 Replacement Components

No	Qty	Description	Manaras-Opera Part #	No	Qty	Description	Manaras-Opera Part #
1	1	#50 CONNECTING LINK 50-1	LINK011	7	1	PIN COTTER 1/8 X 1-1/2	PIN001
2	1	ADJUSTMENT BRAKE LEVER	LEVER064	8	1	PLATED BRAKE PLATE	PLATE084
3	1	BRAKE BAND ASSEMBLY HEAVY DUTY	BRAKEPART019	9	1	PLATED SOLENOID COVER	COVER048
4	1	BRAKE DRUM	DRUM005	10	1	SOLENOID	SEE Table 19
5	1	BRAKE LEVER	LEVER065	11	1	TROLLEY ARM DISCONNECT SPRING	SPRING026
6	1	BRAKE LEVER PIVOT	BUSHING053				

### 4.3 OTH / OTBH Control Box with BOARD 070E

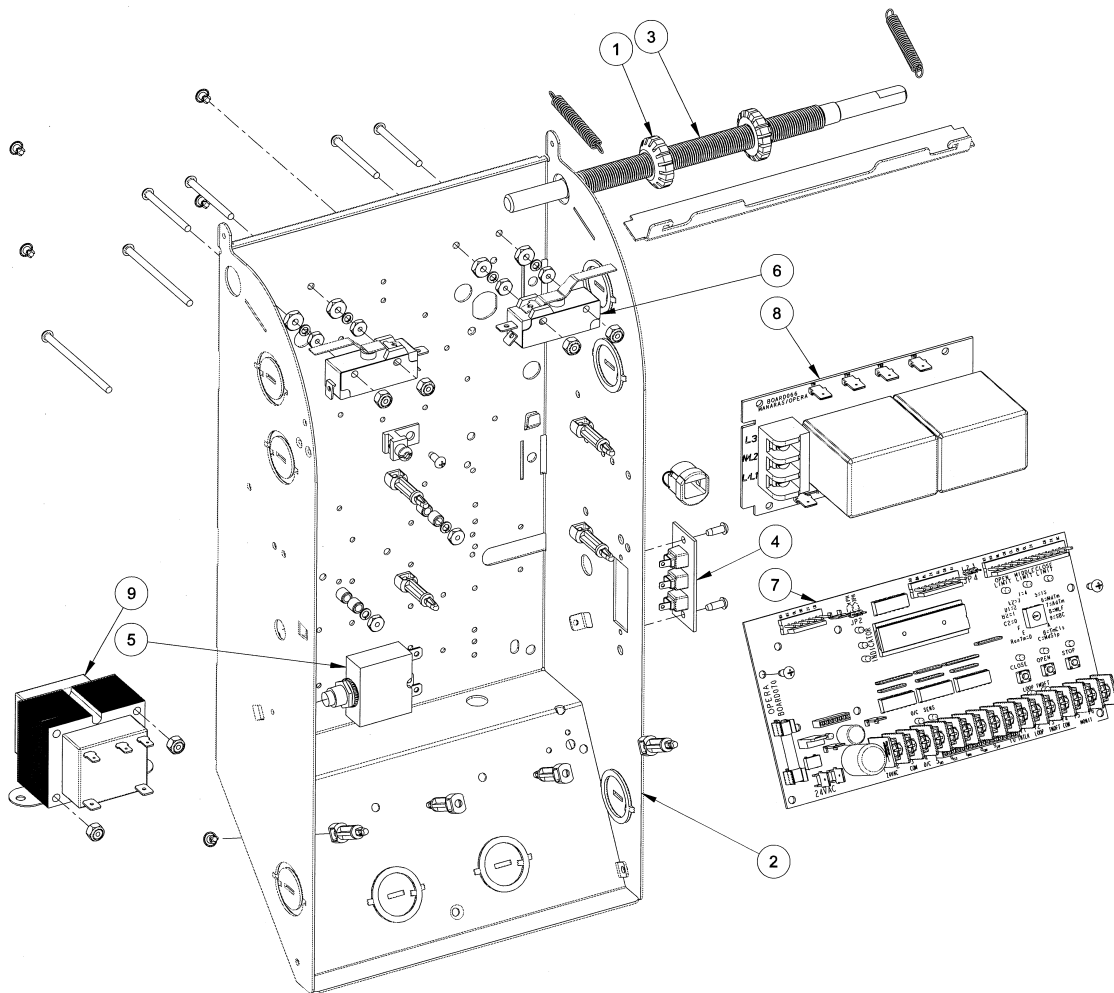

Figure 34 - OTH / OTBH Control Box with BOARD 070E

Table 18 - Control Box Replacement Components (CBOX030)

No	Qty	Description	Manaras-Opera Part #
1	2	CAM LIMIT OPERA	CAM011
2	1	OPERA CONTROL BOX "D" HOLES	CBOX030
3	1	OPERA LIMIT SHAFT	SHAFT103
4	1	RADIO CONTROL TERM STRIP	TSTRIP005
5	1	RESET	SEE Table 19
6	2	SINGLE LIMIT SWITCH - LEVER 46 DEG	LIMIT023
7	1	MONITORING STD ELECT. CONTR. BOARD	BOARD070E
8	1	STD ELECT. POWER BOARD 2 RELAYS	BOARD066
9	1	TRANSFO TO 24V	SEE Table 19

## 4.4 Replacement Motors, Transformers, Solenoids and Resets

Table 19 - OTH / OTBH Replacement Motors, Transformers, Solenoids and Resets According to Voltage/Phase and HP

V-PH	HP	Transfo.	Solenoid	Description	Manaras-Opera Part #
120V - 1PH	1/2HP	TRANSF143	SOLENOID001	MOTOR 1/2HP - 120V/230V - 1PH	MOTOR254
				1PH - 10 AMPS RESET	RESET007
	3/4HP			MOTOR 3/4HP - 120V/230V - 1PH	MOTOR255
				1PH - 15 AMPS RESET	RESET012
	1HP			MOTOR 1HP - 120V/230V - 1PH	MOTOR256
				1PH - 17 AMPS RESET	RESET014
230V - 1PH	1/2HP	TRANSF143	SOLENOID002	MOTOR 1/2HP - 120V/230V - 1PH	MOTOR254
				1PH - 5 AMPS RESET	RESET002
	3/4HP			MOTOR 3/4HP - 120V/230V - 1PH	MOTOR255
				1PH - 7 AMPS RESET	RESET004
	1HP			MOTOR 1HP - 120V/230V - 1PH	MOTOR256
				1PH - 9 AMPS RESET	RESET006
208V - 3PH	1/2HP	TRANSF037	SOLENOID003	MOTOR 1/2HP - 208V/460V - 3PH	MOTOR271
	3/4HP			MOTOR 3/4HP - 208V/460V - 3PH	MOTOR273
	1HP			MOTOR 1HP - 208V/460V - 3PH	MOTOR275
460V - 3PH	1/2HP	TRANSF088	SOLENOID003	MOTOR 1/2HP - 208V/460V - 3PH	MOTOR271
	3/4HP			MOTOR 3/4HP - 208V/460V - 3PH	MOTOR273
	1HP			MOTOR 1HP - 208V/460V - 3PH	MOTOR275
575V - 3PH	1/2HP	TRANSF142	SOLENOID004	MOTOR 1/2HP - 575V - 3PH	MOTOR272
	3/4HP			MOTOR 3/4HP - 575V - 3PH	MOTOR274
	1HP			MOTOR 1HP - 575V - 3PH	MOTOR276

# Notes



# Notes





# Notes



# Notes



## **Warranty**

Manaras-Opera warrants its operators to be free from defects in material and workmanship under normal and proper use for a period of two years from date of invoice, unless otherwise stated. Mechanical, electrical and electronic accessories are warranted for one year from date of invoice, unless otherwise stated. Wearing parts such as clutch pads, v-belts, and brake bands are excluded from warranty.

Manaras-Opera's only obligation shall be to repair or replace defective equipment which does not conform to the warranty. Manaras-Opera shall not be liable for any injury, loss or damage, direct or consequential, arising out of the inability to use the equipment. Before using, Buyer and/or the ultimate User shall determine the suitability of the product for its intended use, and User assumes all risks and liability in connection therewith. The foregoing may not be changed except by an Agreement signed by an authorized representative of Manaras-Opera.

The articles that are replaced pursuant to the terms of this warranty shall be retained by Manaras-Opera, and the User is responsible for any freight costs relating to repair or replacement.

The foregoing warranty is exclusive and in lieu of all other warranties of quality, whether written, oral or implied (including any other warranty of merchantability or fitness for purpose).

The following are exclusions from warranty:

- If usage, product modification, adaptation or installation are not in accordance with our installation and operating instructions.
- If the product has been opened, dismantled or returned with clear evidence of abuse or other damage.
- If our written specifications are not properly applied by the Buyer when selecting the equipment.
- If our written instructions for installation and wiring of the electrical connections have not been followed.
- If our equipment has been used to perform functions other than the functions it was designed to handle.
- If Manaras-Opera equipment is used with electrical accessories (switches, relays, etc.) that have not been previously approved in writing by the Manaras-Opera Engineering Department.
- If electrical accessories and other components have been used in disregard of the basic wiring diagram for which they were designed.

All costs related to installation and re-installation of the Manaras-Opera equipment covered by this warranty are not the responsibility of Manaras-Opera. Manaras-Opera will not be responsible for any consequential damages following installation procedures performed by the Buyer or the User. If the Buyer resells any Manaras-Opera products to another Buyer or User, it shall include all of the terms and provisions of this warranty in such resale. Manaras-Opera's responsibility to any such Third Party shall be no greater than Manaras-Opera's responsibility under the warranty to the original Buyer.

### **Returns**

No returns will be accepted without prior written authorization by Manaras-Opera. All returns must be accompanied by a Return Authorization Number issued by Manaras-Opera, and all unauthorized returns will be refused. The return shipment is to be freight prepaid by the Buyer, and under no circumstances shall the Buyer deduct the value of the returned merchandise from any remittance due. A restocking fee of 15% of the Manaras-Opera sale price will be charged for all returns not covered under warranty.

# 2X FASTER\*



## RAPIDO™ TWICE AS FAST

**OPEN AND CLOSE YOUR DOOR TWICE AS FAST WITH A RAPIDO OPERATOR FROM MANARAS-OPERA.**

The RAPIDO™ features a door speed up to 2 times faster than standard models available to the commercial and industrial door market.

The RAPIDO™ increases the longevity of the complete door system, designed to speed-up industrial standard lift sectional doors while smoothly managing soft-starts and soft-stops.

**CHOOSING THE RAPIDO™ IS SIMPLE WHEN TIME AND ENERGY SAVINGS IS A MUST.**

On-board control and monitoring of external entrapment protection devices, provide speed managing features and enhanced performance and reliability.

\*The RAPIDO™ operator is up to 2X the speed of a standard jackshaft operator.

CALL US FOR MORE INFORMATION: 1-800-361-2260

[www.manaras.com](http://www.manaras.com)



- MEMBER OF THE CANIMEX GROUP -